



arflex
italian design story

PRODUCTS INDEX

SOFAS

9000
Arcolor
Ben Ben
Bobo
Bonsai
Casablanca
Claudine
Cousy
Cradle
Deep Cradle
Edo
Faubourg
Frame
Hall
Hollywood
Hug love seat
K2
K2 Extra
Leenus
Marechiaro
Marenco
Naviglio
Pecorelle
Rendez-Vous
Strips
Strips 77
Tokio

ARMCHAIRS

Algon
Boborelax
Botolo
Brigitte
Cocca
Cradle
Delfino
Delta Vienna
Elettra
Fiorenza
Giulietta
Hall
Hug
Jules
Jim
Katrin
Ladle
Pecorelle
Solice
Suppli
Taboga
Yuzu

CHAIRS AND STOOLS

Botolo
Elettra
Lizzy
Neptunia
Orfeo

BEDS

Palazzo
Strips
Strips sofa-bed
Suite

SMALL TABLES

Arcolor
Bonsai
Capilano
Cradle
Marea
Match
Sigmund
Tablet
Tokio
Tokio modules

BOOKCASES

Alba

ACCESSORIES AND COMPLEMENTS

Ciclope
Delfino pouf
Diva
Match console
Papillon
Penta pouf
Ponti
Pouf
Radia wall hanging
Sigmund bench
Sigmund daybed
Solice pouf
Threshold
Vela
Yuzu pouf

OUTDOOR

Marenco outdoor
Taboga outdoor



arflex DESIGN STORIES

arflex programma un percorso che attraversa l'Italia per riscoprire, riassaporare la storia della cultura artigianale del saper fare.

Si relaziona attraverso architetture storiche e moderne, dove incontra persone diverse, che custodiscono esperienze di respiro internazionale. arflex porta in questo viaggio la sua capacità di sintesi tra design, qualità, uso e cuore, creando luoghi di conversazione, di confronto, di divertimento e tutto diventa subito una grande famiglia. Condividiamo con voi, che collaborate con arflex, le immagini realizzate.

arflex plans a journey through Italy, to rediscover and savour the history of expert artisan culture. It encompasses historical and modern architecture, meeting different people, who are the guardians of international taste and ideas. arflex brings to this journey its ability to synthesize design, quality, use and heart. Everything immediately becomes a big family, by creating places of conversation, confrontation and fun. We share with you, who collaborate with arflex, the realized images.



CASABLANCA / sofa
BOBORELAX / chaise longue
capsule collection Line 3
category T6
MATCH / small table



CASABLANCA / sofa





BOBORELAX / chaise longue
capsule collection Line 3
category T6





CASABLANCA / sofa
DELFINO / armchair
DELFINO / pouf
TABLET / small table
VELA / screen

CASABLANCA / sofa
VELA / screen



CASABLANCA / sofa
TABLET / small table



BOBO / sofa
MARENCO / armchair
DELTA VIENNA / armchair
TABLET / small table



MARENCO / armchair



BOBO / sofa
TABLET / small table



STRIPS 77 / sofa
STRIPS 77 / armchair





STRIPS 77 / sofa
STRIPS 77 / armchair



STRIPS 77 / sofa
BRIGITTE BERGÈRE / armchair
MATCH / small table



TABOGA / armchair
BRIGITTE BERGÈRE / armchair
ARCOLOR / small table
VELA / screen



BRIGITTE BERGÈRE / armchair
VELA / screen





NAVIGLIO / sofa
NAVIGLIO / pouf
BRIGITTE / armchair



BRIGITTE / armchair



STRIPS 77 / sofa
TABOGA / armchair
capsule collection
Line 6 category T6
MATCH / small table



STRIPS 77 / sofa

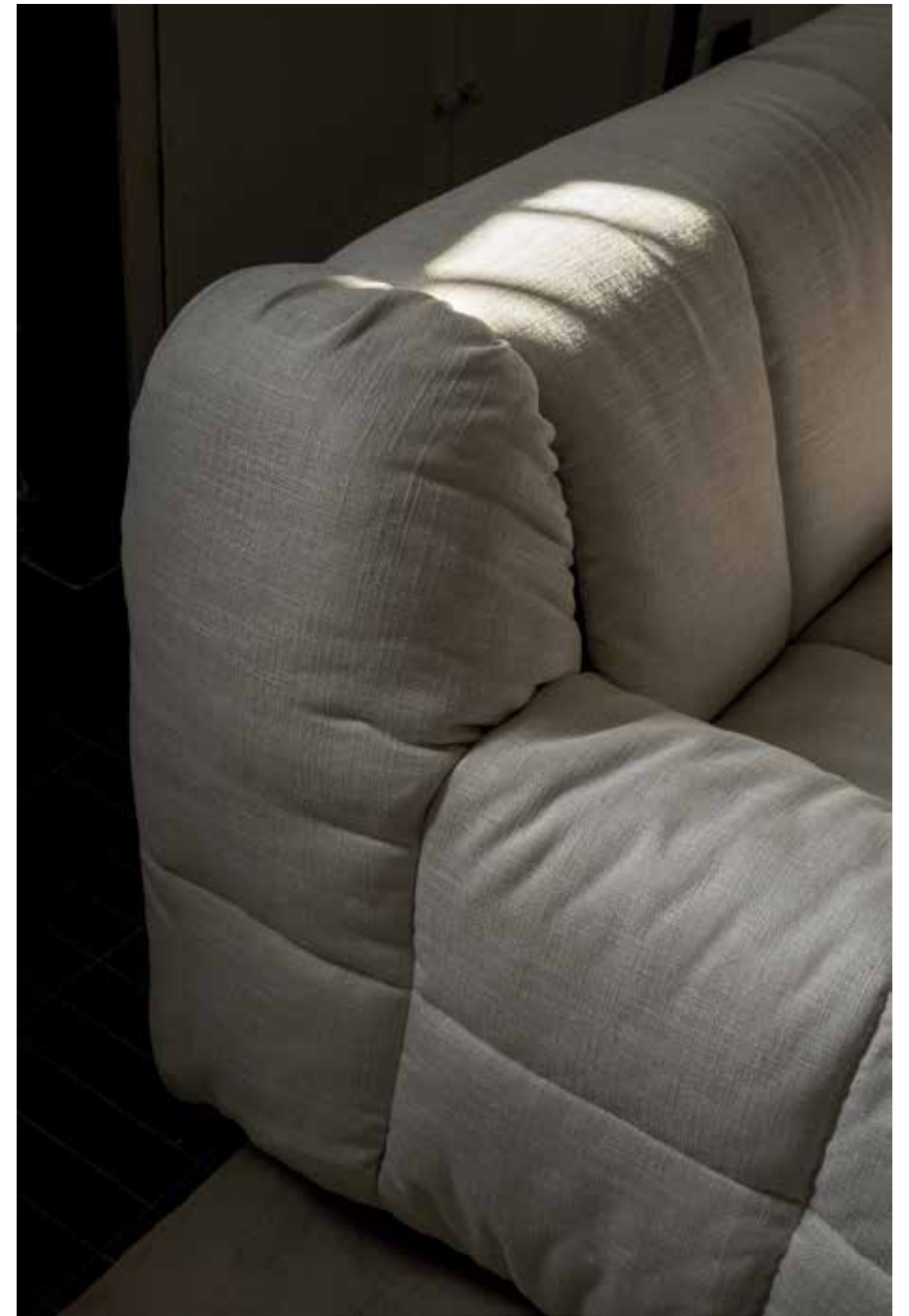



STRIPS 77 / sofa
SOLICE / armchair
MATCH / small table





SOLICE / armchair
SOLICE / pouf





STRIPS / sofa-bed



MAREA / small table





EDO
BY CLAESSION KOIVISTO RUNE

IL SISTEMA DI SEDUTE EDO SI RICOLLEGA ALLA COLLEZIONE TOKIO, ANCHE SE LA COSTRUZIONE INTERNA E' STATA RIPROGETTATA, PER RAGGIUNGERE UN GRADO DI COMFORT SEMPRE PIU' ELEVATO.

PRENDE IL NOME DALLA CAPITALE DEL GIAPPONE DEL XII SECOLO.

I GIAPPONESI HANNO STORICAMENTE UTILIZZATO FORME PIU' MORBIDE E ORGANICHE NEI LORO GIARDINI, NEL DESIGN INDUSTRIALE E NELL'ARCHITETTURA. DI SOLITO SI RIFERISCONO AL TOCCO TATTILE DI UN OGGETTO ARROTONDATO. ABBIAMO QUINDI PENSATO CHE FOSSE UN NOME APPROPRIATO PER LA COLLEZIONE EDO.

THE NEW EDO SOFA SYSTEM IS RELATED TO TOKIO COLLECTION, ALTHOUGH THE INTERNAL CONSTRUCTION HAS BEEN COMPLETELY REENGINEERED, TO BE ABLE TO REACH AN EVER HIGHER DEGREE OF COMFORT.

IT TAKES ITS NAME FROM THE 17TH CENTURY NAME OF THE CAPITAL OF JAPAN. THE JAPANESE HAVE HISTORICALLY USED SOFTER AND MORE ORGANIC FORMS IN THEIR GARDENS, INDUSTRIAL DESIGN AND ARCHITECTURE, USUALLY REFERRING TO THE TACTILE TOUCH OF A ROUNDED OBJECT. WE THEREFORE THOUGHT IT WOULD BE A FITTING NAME FOR THE EDO COLLECTION.

EDO / sofa composition E 28
DELTA VIENNA / armchair



EDO / sofa composition E 28
DELTA VIENNA / armchair
TABLET / small table
YUZU / armchair



EDO / sofa composition E 29
YUZU / armchair
TOKIO / small table





EDO / sofa composition E 29
TOKIO/ open storage module



EDO / sofa composition E 29
TOKIO/ open storage module
TOKIO / small table



EDO / sofa composition E 24
JULES / armchair
TOKIO / small table



EDO / sofa
composition E 24

EDO / sofa composition E 30
TOKIO/ open storage module
TOKIO / small table
TOKIO / service

MARENCO / armchair
ARCOLOR / small table
RADIA / wall hanging



EDO / sofa
CRADLE / armchair
CRADLE / small table
RADIA / wall hanging



CRADLE / armchair



EDO / sofa
CRADLE / small table



EDO / sofa composition E 36
YUZU / armchair
TOKIO / small table
TOKIO / service
ARCOLOR / small table





EDO / sofa composition E 24/B
TOKIO / open storage module



EDO / sofa composition E 24/C
TOKIO / open storage module



EDO / sofa composition E 24/D
TOKIO / module with shelf

EDO / sofa composition E 34/B



EDO / sofa composition E 34
TABLET/ small table
TOKIO / module with drawer
SIGMUND / small table
ELETTRA / armchair – capsule collection Dedale 3
ALBA / bookcase composition – wall fixing version



EDO / sofa composition E 34
TOKIO / module with shelf
TABLET/ small table
ELETTRA / armchair – capsule collection Dedale 3
ALBA / bookcase composition – wall fixing version





MARENCO
BY MARIO MARENCO

IL DESIGN INCONFONDIBILE E L'AMPIA MODULARITÀ FANNO ANCORA DEL DIVANO MARENCO UN MUST DELL'ARREDAMENTO CONTEMPORANEO. DISEGNATO DA MARIO MARENCO NEL 1970, RIMANE SEMPRE UN GRANDE CLASSICO DEL DESIGN ITALIANO. CON QUESTO DIVANO DAI GRANDI CUSCINI ARROTONDATI, MARIO MARENCO HA UNITO FORZA E COMFORT. NEL 2007 MARENCO HA VINTO IL WALLPAPER DESIGN AWARDS BEST REISSUES. THE UNMISTAKABLE DESIGN AND WIDE MODULARITY STILL MAKE MARENCO SOFA A MUST-HAVE IN CONTEMPORARY FURNITURE. DESIGNED BY MARIO MARENCO IN 1970, IT ALWAYS REMAINS A GREAT CLASSIC OF THE ITALIAN DESIGN. WITH THIS LARGE-ROUNDED CUSHIONS SOFA, MARIO MARENCO HAS COMBINED STRENGTH AND COMFORT. IN 2007 MARENCO WON THE WALLPAPER DESIGN AWARDS BEST REISSUES.





MARENCO / sofa
BONSAI / small table



MARENCO / sofa
ELETTRA / armchair – capsule collection Teddy 02
category Leather Super



MARENCO / sofa -
capsule collection
Line 3 category T6
MARENCO / armchair



MARENCO / armchair

MARENCO / armchair
ALBA / bookcase composition – wall fixing version



MARENCO / armchair
ARCOLOR / small table



MARENCO / sofa
MARENCO / armchair
DELTA VIENNA / armchair
ARCOLOR / small table
TABLET / small table





ELETTRA
BY B.B.P.R.

IL PRIMO GRANDE PROGETTO DI B.B.P.R. RISALE AL 1946, DOPO LA PARENTESI BELLICA E LA PIANIFICAZIONE DELLA RICOSTRUZIONE PER MILANO. ACCANTO AI MOBILI PER LA CASA, GLI ANNI '50 VEDONO ANCHE LA REALIZZAZIONE DEI PRIMI ARREDI PER UFFICI E SPAZI PUBBLICI, COME IL MODELLO ELETTRA.

B.B.P.R.'S FIRST MAJOR DESIGN PROJECT DATES BACK TO 1946, AFTER THE WAR INTERLUDE AND THE RECONSTRUCTION PLANNING FOR MILAN. ALONGSIDE FURNITURE FOR HOME, THE 1950S ALSO SAW THE CREATION OF THE FIRST FURNISHINGS FOR OFFICES AND PUBLIC SPACES, SUCH AS ELETTRA MODEL.

ELETTRA /armchair





ELETTRA / armchair - capsule collection
Teddy 02 category Leather Super

ELETTRA /armchair





DELFINO
BY ERBERTO CARBONI

LA POLTRONA DELFINO È UN ESEMPIO SIGNIFICATIVO DEL SETTORE DEL MOBILE COSIDDETTO “ORGANICO”, CHE SI SVILUPPA NEGLI ANNI CINQUANTA E CHE SPESSO TRAE ISPIRAZIONE DALLE FORME DELLA NATURA, EVITANDO OGNI IMITATIVO FRAINTENDIMENTO. DELFINO ARMCHAIR IS A SIGNIFICANT EXAMPLE OF SO-CALLED “ORGANIC” FURNITURE FIELD, WHICH DEVELOPS IN THE FIFTIES AND WHICH OFTEN DRAWS ITS INSPIRATION BY THE NATURE SHAPES, AVOIDING ANY IMITATIVE MISUNDERSTANDING.





DELFINO / armchair
DELFINO / pouf





MARECHIARO
BY MARIO MARENCO

L'ESTREMA ESSENZIALITÀ RENDE ANCORA OGGI IL DIVANO MARECHIARO, DISEGNATO NEL 1976 DALL'ARCHITETTO MARIO MARENCO, UN PRODOTTO FORTEMENTE CONTEMPORANEO, DALL'ASPETTO INFORMALE E DAL COMFORT RILASSANTE. UN SISTEMA DI SEDUTE componibile, CHE PERMETTE DI CREARE COMPOSIZIONI DINAMICHE, DALLE LINEE GEOMETRICHE A QUELLE CURVE, ADATTANDOSI SIA ALLA ZONA LIVING CHE ALL'HOSPITALITY.

THE EXTREME ESSENTIALITY STILL MAKES MARECHIARO SOFA, DESIGNED IN 1976 BY THE ARCHITECT MARIO MARENCO, A HIGHLY CONTEMPORARY PRODUCT, WITH AN INFORMAL LOOK AND RELAXING COMFORT. A MODULAR SEATING SYSTEM, THAT ALLOWS TO CREATE DYNAMIC COMPOSITIONS, FROM GEOMETRIC TO CURVED LINES, ADAPTING TO BOTH LIVING AND HOSPITALITY AREAS.

MARECHIARO / sofa composition MH 11





MARECHIARO / sofa composition MH 10
MATCH / small table
CRADLE / armchair

MARECHIARO / sofa composition MH 10



MARECHIARO / sofa composition MH 12



MARECHIARO / sofa
CRADLE / armchair
BOTOLO / armchair
BONSAI / small table
ALBA / bookcase
composition - ceiling
fixing version





FIorenza
BY FRANCO ALBINI

IN UNA PAGINA PUBBLICITARIA PIRELLI DEGLI ANNI CINQUANTA, LA POLTRONA FIORENZA, DISEGNATA DA FRANCO ALBINI NEL 1952, È STATA UTILIZZATA COME IMMAGINE SIMBOLO DELLE POTENZIALITÀ DELLA GOMMAPIUMA, CHE CALZA A PENNELLO E, ALL'EPOCA, ERA IL MATERIALE TECNOLOGICAMENTE PIÙ AVANZATO UTILIZZATO NEGLI IMBOTTITI. IN A FIFTIES' PIRELLI ADVERTISING PAGE, FIORENZA ARMCHAIR, DESIGNED BY FRANCO ALBINI IN 1952, HAS BEEN USED AS A SYMBOL IMAGE OF FOAM RUBBER'S POTENTIAL, WHICH FITS LIKE A GLOVE AND, AT THAT TIME, WAS THE MOST TECHNOLOGICALLY ADVANCED MATERIAL USED IN UPHOLSTERED FURNITURE.

FIorenza / armchair
SIGMUND / small table





FIORENZA / armchair





FIORENZA / armchair - capsule collection Teddy 10
category Leather Super
POUF



STRIPS BY CINI BOERI

ALL'INIZIO DEGLI ANNI SETTANTA, L'ARCHITETTO CINI BOERI HA RIVOLUZIONATO IL MERCATO DEL MOBILE CON IL SUO MODELLO, CHE RESTA OGGI UN "EVERGREEN": IL DIVANO COMPONIBILE STRIPS, CHE APPARTIENE ALLA STORIA DI ARFLEX. SICURAMENTE È UNO DEI PRODOTTI PIÙ FAMOSI, DISEGNATO NEL 1968, PREMIATO CON IL COMPASSO D'ORO ED È ESPOSTO IN DIVERSI MUSEI DEL MONDO, COME LA TRIENNALE DI MILANO, A TOKYO, IL MOMA DI NEW YORK.

AT THE BEGINNING OF THE SEVENTIES, THE ARCHITECT CINI BOERI REVOLUTIONIZED THE FURNITURE MARKET WITH HER MODEL, THAT STAYS NOWADAYS AN "EVERGREEN": THE MODULAR SOFA STRIPS, WHICH BELONGS TO ARFLEX HISTORY. SURELY IT IS ONE OF THE MOST FAMOUS PRODUCTS, DESIGNED IN 1968, WHICH AWARDED THE PRIZE COMPASSO D'ORO AND IT IS DISPLAYED IN SEVERAL MUSEUMS ALL OVER THE WORLD, SUCH AS TRIENNALE IN MILAN, IN TOKYO, MOMA IN NEW YORK.

STRIPS / sofa composition S 20
SIGMUND / small table





STRIPS / sofa composition S 15
STRIPS / pouf
CRADLE / small table

STRIPS / sofa composition S 3
HALL / armchair - capsule collection Riga 01 category T6
SIGMUND / small table



STRIPS / sofa
composition S 18



STRIPS / sofa
composition S 19



STRIPS / sofa
composition S 20



STRIPS / sofa
composition S 21
STRIPS / pouf
DELFINO / armchair
MATCH / small table





STRIPS / sofa composition S 21
TOKIO / module with shelf



STRIPS / sofa
ARCOLOR / small table





LEENUS

BY FABRIZIO BALLARDINI

IL SISTEMA DI SEDUTE LEENUS È L'ULTIMO NATO DELLA FAMIGLIA LEE E LOW LAND, PROGETTATE DALL'ARCH. BALLARDINI, PER PERMETTERE UN ALTO POTENZIALE DI PROGETTUALITÀ, OLTRE A MOLTE POSSIBILITÀ DI COMBINAZIONI, PER RISPONDERE AI VARI GUSTI STILISTICI DELLO SPAZIO LIVING.

LEENUS HA UN ASPETTO ACCATTIVANTE, GENEROSO E CONFORTEVOLE, GRAZIE AL GIOCO DI SOVRAPPOSIZIONE DEI CUSCINI DI SCHIENALE E AI DIVERSI MODULI COMBINABILI TRA LORO, CHE PERMETTONO DI REALIZZARE COMPOSIZIONI CON UN ELEGANTE MOVIMENTO DI VOLUMI.

LEENUS SEATING SYSTEM IS THE LATEST ADDITION TO LEE AND LOW LAND FAMILY, DESIGNED BY THE ARCHITECT BALLARDINI, IN ORDER TO ALLOW A HIGH POTENTIAL DESIGN, AS WELL AS MANY COMBINATION POSSIBILITIES, TO MEET THE VARIOUS STYLISTIC TASTES OF THE LIVING SPACE.

LEENUS HAS AN APPEALING, GENEROUS AND COMFORTABLE LOOK, THANKS TO THE PLAY OF OVERLAPPING BACK CUSHIONS AND THE DIFFERENT MODULES, THAT CAN BE COMBINED EACH OTHER, ALLOWING THE REALITISATION OF COMPOSITIONS WITH AN ELEGANT MOVEMENT OF VOLUMES.

LEENUS / sofa composition LU 05
ELETTRA / armchair





LEENUS / sofa composition LU 05
ELETTRA / armchair
TABLET / small table
TOKIO / service
MATCH / console

LEENUS / sofa composition LU 07
TOKIO / service
ARCOLOR / small table
CAPILANO / small table
RADIA / wall hanging





LEENUS / sofa composition LU 01



LEENUS / sofa composition LU 02
TOKIO / module with shelf
TOKIO / small table
TOKIO / service
BOTOLO / armchair – capsule collection Tiger 02





SUPPLÌ
BY LUCA NICHETTO

SUPPLÌ È UNA POLTRONA INVITANTE ED ELEGANTE. LE CURVE MORBIDE E SINUOSE EMANANO CALORE E INCARNANO UN'ANCORA SPAZIALE QUASI PERFETTA PER IL RIPOSO E IL RELAX.
SUPPLÌ IS AN INVITING AND ELEGANT ARMCHAIR. SOFT AND SINUOUS CURVES EXUDE WARMTH AND EMBODY A NEAR PERFECT SPATIAL ANCHOR FOR REST AND RELAXATION.

SUPPLÌ / armchair
TABLET / small table





SUPPLÌ / armchair

SUPPLÌ / armchair
SIGMUND / small table





CRADLE BY NERI&HU

LA POLTRONA E IL DIVANO ATTINGONO SIA DALLA RICCA STIRPE DEL MOBILE ITALIANO, NOTO PER LE SUE FORME SCULTOREE E AUDACI, SIA DALLA SENSIBILITÀ MODERNISTA, CHE RICHIEDE UN'ONESTA ESPRESSIONE STRUTTURALE. PIUTTOSTO CHE NASCONDERE IL TELAIO E TENTARE DI SOLLEVARE I MODELLI DA TERRA, GLI ELEGANTI ELEMENTI DI SUPPORTO REALIZZATI A MANO DIVENTANO ESSI STESSI IL PUNTO FORTE DEL PRODOTTO.

THE ARMCHAIR AND THE SOFA DRAW BOTH FROM THE RICH LINEAGE OF ITALIAN FURNITURE, KNOWN FOR ITS SCULPTURAL AND BOLD SHAPES, AS WELL AS FROM THE MODERNIST SENSIBILITY, THAT DEMANDS A HONEST STRUCTURAL EXPRESSION. RATHER THAN CONCEAL THE FRAME AND ATTEMPT TO MAKE THE MODELS LIFT FROM THE GROUND, THE ELEGANT CRAFTED SUPPORTING ELEMENTS BECOME THEMSELVES THE HIGHLIGHT OF THE PRODUCT.

CRADLE / armchair
CAPILANO / small table



CRADLE / sofa
CRADLE / armchair
CRADLE / service
SIGMUND / small table
DELFINO / pouf
PAPILLON / wall lamp
PENTA / pouf





CRADLE / armchair



CRADLE / sofa



CRADLE / armchair

DEEP CRADLE / sofa
CRADLE / small table





9000
BY TITO AGNOLI

ALLA FINE DEGLI ANNI '60, I DESIGNER INIZIANO A REALIZZARE MOBILI MINI E VERSATILI, PENSATI PER SPAZI DOMESTICI COMPATTI E MULTITASKING. ARFLEX, DA SEMPRE IMPEGNATA IN UN COSTANTE LAVORO DI RICERCA E REALIZZAZIONE, PRESENTA 9000, DI TITO AGNOLI, UNA SERIE DI SEDUTE CONTENUTE E VARIAMENTE ARTICOLATE. LE RIDOTTE DIMENSIONI E LA FACILE COMPONIBILITÀ RAPPRESENTANO UNA VALIDA SOLUZIONE A DIVERSE PROBLEMATICHE DI ARREDO, SIA PER AMBIENTI DOMESTICI CHE COLLETTIVI.

AT THE END OF THE 60'S, THE DESIGNERS STARTED REALIZING MINI AND VERSATILE FURNITURE, CONCEIVED FOR SMALL AND MULTITASKING DOMESTIC SPACES. ARFLEX, ALWAYS ENGAGED IN A CONSTANT WORK OF RESEARCH AND REALIZATIONS, PRESENTS 9000, BY TITO AGNOLI, A SERIES OF COMPACT AND VARIOUSLY ARTICULATED SEATS. THE CONTAINED DIMENSIONS AND THE EASY MODULARITY REPRESENT A VALID SOLUTION TO DIFFERENT FURNISHING PROBLEMS, BOTH FOR HOME AND COLLECTIVE ENVIRONMENTS.

9000 / sofa composition NV 03



9000 / sofa composition NV 11
9000 / armchair
SIGMUND / small table





9000 / sofa
9000 / pouf
BONSAI / small table
ARCOLOR / small table
SUPPLI / armchair



9000 / sofa composition NV 02



9000 / sofa composition NV 14
TABLET / small table
ARCOLOR / small table

9000 / armchair
TOKIO / sofa
TOKIO / open storage module
TOKIO / small table



9000 / sofa



9000 sofa
composition
NV 04



9000 / sofa
composition
NV 06



9000 / sofa
composition
NV 09



9000 / sofa
composition
NV 08



9000 / sofa
composition
NV 13



9000 / sofa
composition
NV 12



9000 / sofa
composition
NV 11



9000/ sofa
composition
NV 10



9000 / armchair
ALBA / bookcase composition - ceiling fixing version





THRESHOLD
BY NERI&HU

LA PAROLA CINESE “JIAN” PUÒ ESSERE TRADOTTA IN “SPAZIO” O “INTERVALLO”, MA È ANCHE LA PAROLA UNITARIA PER UNA “STANZA”. IN SENSO ARCHITETTONICO, QUESTO TERMINE PUÒ ESSERE INTESO COME UNA CONDIZIONE DI SOGLIA - LA MEDIAZIONE FISICA TRA DUE AMBIENTI SPAZIALI CONTRASTANTI, COME L’INTERIORITÀ E L’ESTERIORITÀ, O PUBBLICO E PRIVATO - MA IMPLICA ANCHE CHE LA SOGLIA NON SIA UN MECCANISMO PASSIVO, AVENDO IL POTENZIALE PER ALTERARE ATTIVAMENTE CONFIGURAZIONI E RELAZIONI SPAZIALI.

THE CHINESE WORD “JIAN” CAN BE TRANSLATED INTO “GAP” OR “INTERVAL”, BUT IT IS ALSO THE UNIT WORD FOR A “ROOM”. IN AN ARCHITECTURAL SENSE, THIS TERM CAN BE UNDERSTOOD AS A THRESHOLD CONDITION – THE PHYSICAL MEDIATION BETWEEN TWO CONTRASTING SPATIAL ENVIRONMENTS, SUCH AS INTERIORITY AND EXTERIORITY, OR PUBLIC AND PRIVATE – BUT IT ALSO IMPLIES THAT THE THRESHOLD IS NOT A PASSIVE MECHANISM, HAVING THE POTENTIAL TO ACTIVELY ALTER SPATIAL CONFIGURATIONS AND RELATIONSHIPS.

THRESHOLD / low mirror cabinet
BOTOLO / armchair





154 / design collection



THRESHOLD / high mirror cabinet
SIGMUND / bench

155 / design collection



LADLE
BY LUCA NICHETTO

LE POLTRONE LADLE VOGLIONO RIELABORARE IL DESIGN IN CHIAVE CONTEMPORANEA, MA SOPRATTUTTO LA SENSAZIONE E IL COMFORT DELLE POLTRONE CLASSICHE DEGLI ANNI '60. LADLE (CHE SIGNIFICA MESTOLO), COME IL GRANDE CUCCHIAIO DI LEGNO, RACCOGLIE LA FORMA DEL CORPO, REGALANDO UN COMFORT MOLTO MORBIDO E AVVOLGENTE.

THE ARMCHAIRS LADLE WANT TO RE-EDIT THE DESIGN WITH A CONTEMPORARY POINT OF VIEW, BUT ABOVE ALL THE FEELING AND THE COMFORT OF THE 60' YEARS CLASSIC ARMCHAIRS. LADLE, LIKE THE BIG WOODEN SPOON, COLLECTS THE BODY SHAPE, GIVING A VERY SOFT AND EMBRACING COMFORT.

LADLE / armchair
LADLE / pouf



LADLE / armchair
SIGMUND / bench
SIGMUND / small table



LADLE / armchair





ALBA
BY BERNHARDT & VELLA

ALBA È UNA LIBRERIA PER ESPORRE E CONTENERE, CON UNA STRAORDINARIA VERSATILITÀ CREATRICE. I RIPIANI IN VETRO COLORATO PERMETTONO DI REALIZZARE COMPOSIZIONI TONDE, GRAZIE AL FISSAGGIO CON UN UNICO ELEMENTO DI GIUNZIONE. L'ELEMENTO SEMICERCHIO IN VETRO COLORATO AGGIUNGE ANCHE UN DECORO GEOMETRICO, OLTRE AD AVERE LA FUNZIONE DI RIPORRE I LIBRI.

ALBA IS A BOOKCASE FOR EXHIBITING AND CONTAINING, WITH AN EXTRAORDINARY CREATING VERSATILITY. THE COLOURED GLASS SHELVES ALLOW TO REALIZE ROUND COMPOSITIONS, THANKS TO THE FIXING WITH ONE SINGLE JOINING ELEMENT. THE COLOURED GLASS HALF CIRCLE-SHAPE ELEMENT ADDS ALSO A GEOMETRIC DECORATION, IN ADDITION TO THE FUNCTION OF HANGING THE BOOKS.





**ALBA / bookcase
composition –
wall fixing version
HALL / armchair**





**ALBA / bookcase composition
ceiling fixing version
BOTOLO / armchair
MARENCO / armchair
ARCOLOR / small table**

ALBA / bookcase
composition -
wall fixing version





ARCOLOR
BY JAIME HAYON

PER SVILUPPARE IL DIVANO ARCOLOR DI ARFLEX, JAIME HAYON HA VOLUTO CREARE UN SISTEMA MODULARE DISEGNATO INTORNO ALLA GEOMETRIA CLASSICA DELL'ARCO.
TO DEVELOP ARCOLOR SOFA FOR ARFLEX, JAIME HAYON WANTED TO CREATE A MODULAR SYSTEM DESIGNED AROUND THE CLASSICAL GEOMETRY OF THE ARCH.

ARCOLOR / sofa composition AR 03



ARCOLOR / sofa composition AR 02
ARCOLOR / small table
TABLET / small table
MATCH / console





TOKIO
BY CLAESSON KOIVISTO RUNE

LA COLLEZIONE SI PUÒ RAGGRUPPARE IN UNA POSSIBILITÀ PRESSOCHÉ INFINITA DI COMBINAZIONI: FREE-STANDING, IN UN GRANDE AMBIENTE COME ISOLA DI SEDUTE OPPURE ANCHE NELLA CONFIGURAZIONE PIÙ TRADIZIONALE DEL DIVANO.
THE COLLECTION CAN BE GROUPED IN AN ALMOST ENDLESS POSSIBILITY OF COMBINATIONS: FREE-STANDING, IN A LARGE ROOM AS A SEATING ISLAND, BUT ALSO GROUPED IN A MORE TRADITIONAL SOFA CONFIGURATION.

TOKIO / sofa composition T 09



TOKIO / sofa composition T 16
9000 / armchair
TOKIO / module with shelf
TOKIO / open storage module
TOKIO / small table
ARCOLOR / small table



TOKIO / sofa composition T 16
TOKIO / module with shelf
TOKIO / open storage module



TOKIO / open storage module



TOKIO / module with shelf



TOKIO / sofa
composition T 13



TOKIO / module with shelf



TOKIO / sofa composition T 21



TOKIO / sofa
composition T 14



TOKIO / module with shelf



TOKIO / sofa composition T 30



TOKIO / sofa
composition T 15



TOKIO / open storage module



TOKIO / sofa



TOKIO / module with drawer



TOKIO / small table



TOKIO / small table



TOKIO / service



TOKIO / service



TOKIO / sofa
composition T 25



TOKIO / sofa
composition



TOKIO / module with drawer

TOKIO / sofa composition T 17/B
TOKIO / open storage module
TOKIO / module with drawer





TOKIO / sofa
composition T 19
capsule collection Beat 2
category Leather Super
TOKIO / open storage module



TOKIO / sofa composition T 19
capsule collection Beat 2
category Leather Super
TOKIO / open storage module
TOKIO / module with drawer

TOKIO / sofa composition T 19
capsule collection Beat 2
category Leather Super
TOKIO / module with drawer
TOKIO / open storage module





HUG
BY CLAESSON KOIVISTO RUNE

UN GESTO AMICHEVOLE E DI ACCOGLIENZA, RICONOSCIBILE, CHE RACCHIUDE TUTTI GLI ASPETTI E PARLA ANCHE DIRETTAMENTE AL CUORE: L'ABBRACCIO. SI VEDE PIÙ CHIARAMENTE NELLA POSIZIONE 'A BRACCIA APERTE' DEI BRACCIOLI E VUOLE ESSERE UN INVITO UNIVERSALE: «VIENI, SIEDITI UN MOMENTO CON ME E TI METTERÒ A TUO AGIO» (CIT. CLAESSON KOIVISTO RUNE).

A FRIENDLY, WELCOMING, RECOGNISABLE GESTURE, THAT ENCOMPASSES ALL OF THE ASPECTS AND ALSO SPEAKS DIRECTLY TO THE HEART: THE HUG. IT IS MORE VISIBLE IN 'OPEN- ARMED' POSITION OF THE ARMRESTS AND IT IS MEANT AS A UNIVERSAL INVITATION: «COME, SIT WITH ME A WHILE AND I'LL PUT YOU AT EASE» (BY CLAESSON KOIVISTO RUNE).

HUG LOVE SEAT / sofa
HUG / armchair





**HUG / armchair – capsule
collection Line 3 category T6**



HUG / armchair
ARCOLOR / small table



HUG LOVE SEAT / sofa



NAVIGLIO
BY UMBERTO ASNAGO

IL SISTEMA DI SEDUTE NAVIGLIO È CONTRADDISTINTO DA UNA FORMA RIGOROSA, MA PIACEVOLMENTE ADDOLCITA NELLE LINEE, GRAZIE AD UN SAPIENTE USO DEI MATERIALI. UN DIVANO LINEARE E COMPONIBILE, CARATTERIZZATO DA UN'ESTETICA LEGGERA E GENEROSA, CHE LO RENDE COMODO NELLE PROPORZIONI E NEGLI SPAZI.
THE SEATING SYSTEM NAVIGLIO IS CHARACTERIZED BY RIGOROUS SHAPE, BUT PLEASANTLY SOFTENED IN THE LINES, THANKS TO A COMPETENT USE OF THE MATERIALS. A LINEAR AND MODULAR SOFA, DISTINGUISHED BY A LIGHT AND GENEROUS AESTHETIC, WHICH MAKES IT COMFORTABLE IN THE PROPORTIONS AND IN SPACES.



NAVIGLIO / sofa
BONSAI / small table

NAVIGLIO / sofa





NAVIGLIO / sofa
TABLET / small table
BOTOLO / armchair



PECORELLE
BY CINI BOERI

L'ARCHITETTO CINI BOERI RACCONTA DI ESSERSI ISPIRATA ALLE OPERE DI CHRISTO VLADIMIROV JAVACHEFF E JEANNE-CLAUDE DENAT DE GUILLEBON, MAESTRI NELL'ARTE DELLA PITTURA DI PAESAGGIO. LA NATURA PREVALE E DIVENTA LA MUSA ISPIRATRICE DI QUESTO PEZZO DI DESIGN.
THE ARCHITECT CINI BOERI TELLS THAT SHE WAS INSPIRED BY THE WORKS OF CHRISTO VLADIMIROV JAVACHEFF AND JEANNE-CLAUDE DENAT DE GUILLEBON, MASTERS IN THE ART OF LANDSCAPE PAINTING. NATURE PREVAILS AND BECOMES THE INSPIRING MUSE OF THIS PIECE OF DESIGN.





PECORELLE / armchair
SIGMUND / small table

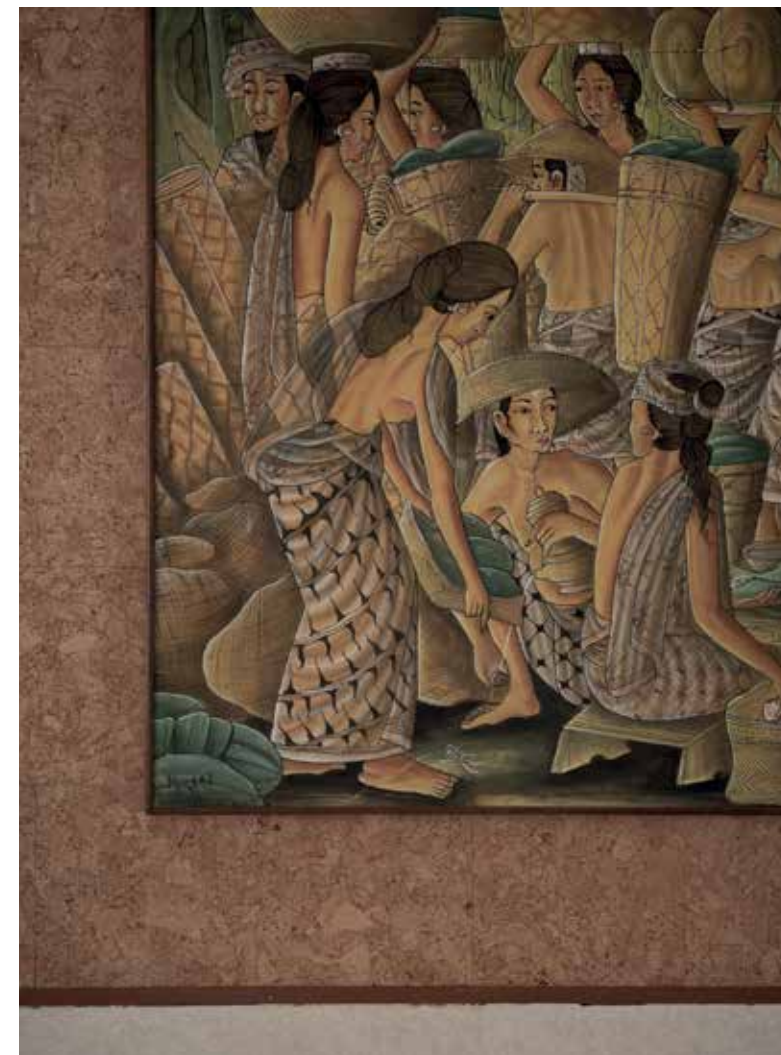



PECORELLE / sofa
MATCH / console



MATCH
BY BERNHARDT & VELLA

IL PROGETTO NASCE DA UN INSIEME INDUSTRIALE DI RIPIANI. LO SNODO IN OTTONE, CHE UNISCE LA STRUTTURA ALLA MENSOLA, DIVENTA UN ELEMENTO PREZIOSO E DECORATIVO. IL SISTEMA PUÒ ESSERE IMPILATO E CON GLI STESSI ELEMENTI SI POSSONO CREARE TAVOLINI, CONSOLE E LIBRERIE DI DIVERSE ALTEZZE.
THE PROJECT WAS BORN FROM AN INDUSTRIAL SHELVES SYSTEM. THE JUNCTION IN BRASS, THAT JOINS THE STRUCTURE WITH THE SHELF, BECOMES A PRECIOUS AND DECORATIVE ELEMENT. THE PIECES CAN BE STACKED AND ALLOWS TO CREATE WITH THE SAME ELEMENTS ALSO SMALL TABLES, CONSOLE AND BOOKSHELVES WITH DIFFERENT HEIGHTS.

MATCH / console





MATCH / console



MATCH / small table



PENTA / pouf
MATCH / console



HALL
BY ROBERTO MENGHI

SIAMO ALLA FINE DEGLI ANNI '50: UN'INTERESSANTE SERIE DI POLTRONE E DIVANI, DISEGNATA DA ROBERTO MENGHI, DENOMINATA HALL, ENTRA A FAR PARTE DELLA COLLEZIONE ARFLEX. IN QUESTI ANNI, IL DESIGN TENDE A NON ESSERE SOLO PER "ÉLITE". CON LA NASCITA DI ALTRE TESTATE SULLA SCIA DI DOMUS, LE MOSTRE SPECIALIZZATE RIESCONO AD AUMENTARE STRATI PIÙ AMPI DI DISTRIBUTORI E PUBBLICO. LA POLTRONA HALL RICEVE NEL 1959 LA MENZIONE D'ONORE PER IL COMPASSO D'ORO.

WE ARE AT THE END OF THE '50S: AN INTERESTING SERIES OF ARMCHAIRS AND SOFAS, DESIGNED BY ROBERTO MENGHI, CALLED HALL, JOINS ARFLEX COLLECTION. IN THESE YEARS, THE DESIGN TENDS NOT TO BE ONLY FOR "ÉLITE". WITH THE BIRTH OF OTHER MAGAZINES IN THE WAKE OF DOMUS, THE SPECIALIZED EXHIBITIONS MANAGE TO RAISE WIDER LAYERS OF DISTRIBUTORS AND AUDIENCE. THE ARMCHAIR HALL RECEIVES IN 1959 THE HONOURABLE MENTION FOR COMPASSO D'ORO.

HALL / armchair – capsule collection Traccia category T5



HALL / armchair
MARENCO / sofa
MATCH / small table



HALL / armchair – capsule collection Riga 001 category T6
SIGMUND / small table



HALL / sofa – capsule
collection Riga 002 category T6
DELTA VIENNA / armchair





BOTOLO
BY CINI BOERI

CINI BOERI DISEGNA BOTOLO NEL 1973, DANDO VITA AD UN NUOVO STILE DI DESIGN, DOVE SI PUÒ SCEGLIERE L'ALTEZZA DELLE GAMBE PER AVERE UNA POLTRONA PRANZO NELLA VERSIONE ALTA O UNO STILE, ALLORA MODERNO, "IL LIVING A BASSO LIVELLO", UN MODO DI VIVERE E DI SEDERSI PER TERRA. NELLE GAMBE CI SONO DELLE RUOTE PER SPOSTARLA FACILMENTE.

CINI BOERI DESIGNED BOTOLO IN 1973, GIVING LIFE TO A NEW DESIGN STYLE, WHERE YOU COULD CHOOSE THE HEIGHT OF THE LEGS TO HAVE A DINING ARMCHAIR IN THE HIGH VERSION OR A STYLE, AT THAT TIME MODERN, "THE LIVING AT A LOW LEVEL", A WAY OF LIVING AND SITTING ON THE GROUND. IN THE LEGS THERE ARE WHEELS TO MOVE IT EASILY.





**BOTOLO / armchair –
capsule collection Tiger 02**

BOTOLO / armchair





**BOTOLO / armchair – capsule
collection Renard 60 category T6**





BOTOLO / armchair
VELA / screen
MATCH / console





COUSY
BY VINCENT VAN DUYSSEN

COUSY, DISEGNATO DA VINCENT VAN DUYSSEN, È CARATTERIZZATO DA LINEE LEGGERE E PROPORZIONATE, CHE LO RENDONO ADATTO A TUTTI I TIPI DI LIVING. UN DIVANO DALLA STRUTTURA MINIMALISTA E RIGOROSA, CON UN EFFETTO CONFORTEVOLE E DECORATIVO ALLO STESSO TEMPO.
COUSY, DESIGNED BY VINCENT VAN DUYSSEN, IS CHARACTERISED BY LIGHT AND PROPORTIONAL LINES, THAT MAKE IT SUITABLE FOR ALL TYPES OF LIVING. A SOFA WITH A MINIMALIST AND RIGOROUS STRUCTURE, FOR A COMFORTABLE AND DECORATIVE EFFECT AT THE SAME TIME.

COUSY / chaise longue
SIGMUND / small table



COUSY / sofa
ELETTRA / armchair
TABLET / small table





YUZU BY CLAESSION KOIVISTO RUNE

YUZU È UNA POLTRONA PICCOLA, MA MOLTO COMODA, CON UNA GRANDE PERSONALITÀ. ICONICA DAL PUNTO DI VISTA DEL DESIGN, ASSOMIGLIA UN PO' A UN PICCOLO E SIMPATICO ANIMALE, O FORSE A UN PERSONAGGIO IMMAGINARIO DEI POKEMON GIAPPONESI.

IL DESIGN ORGANICO E MORBIDAMENTE ARROTONDATO DELLA POLTRONA YUZU COMBINA L'EREDITÀ DEL DESIGN DI LUSO ITALIANO DELLO STORICO MARCHIO ITALIANO ARFLEX, CON UN TOCCO CONTEMPORANEO SCANDINAVO FIRMATO DALLO STUDIO DI ARCHITETTURA SVEDESE CLAESSION KOIVISTO RUNE, CHE COLLABORA CON ARFLEX DA OLTRE UN DECENNIO.

YUZU IS A SMALL - BUT VERY COMFORTABLE - ARMCHAIR WITH A BIG PERSONALITY. DESIGN-WISE ICONIC, AND LOOKING SLIGHTLY LIKE A SMALL AND CUTE ANIMAL, OR MAYBE EVEN A FICTIONAL JAPANESE POKEMON CHARACTER.

THE ORGANIC AND SOFTLY ROUNDED DESIGN OF THE YUZU ARMCHAIR COMBINES THE ITALIAN LUXURY DESIGN HERITAGE FROM HISTORICAL ITALIAN BRAND ARFLEX, WITH A SCANDINAVIAN CONTEMPORARY TOUCH SIGNED BY THE SWEDISH ARCHITECTURAL STUDIO CLAESSION KOIVISTO RUNE, COLLABORATORS WITH ARFLEX SINCE MORE THAN A DECADE.

YUZU / armchair – capsule collection Renard 60 category T6
YUZU / pouf – capsule collection Renard 60 category T6





YUZU / armchair
ARCOLOR / small table





YUZU / armchair
YUZU / pouf





JIM & JULES

BY CLAEISSON KOIVISTO RUNE

PRENDENDO IL NOME DAL FAMOSO FILM FRANCESE DI FRANCOIS TRUFFAUT, JULES & JIM SONO DUE POLTRONCINE CON UN ALTO GRADO DI COMFORT DI SEDUTA. JULES È LA PIÙ PICCOLA E JIM QUELLA PIÙ GRANDE. NONOSTANTE LA DIFFERENZA DI DIMENSIONI, ENTRAMBE LE POLTRONE CONDIVIDONO LA STESSA FORMA (GEOMETRIA ROTONDA), CHE LE RENDE FACILI DA USARE E DA COLLOCARE IN UN CONTESTO ARCHITETTONICO.

NAMED AFTER THE FAMOUS FRENCH MOVIE BY FRANCOIS TRUFFAUT, JULES & JIM ARE TWO EASY CHAIRS WITH A HIGH DEGREE OF SEATING COMFORT. JULES IS THE SMALLER AND JIM THE LARGER ONE. THOUGH THE DIFFERENCE IN SIZE, BOTH ARMCHAIRS SHARE THE SAME SHAPE (ROUND GEOMETRY), WHICH MAKES THEM EASY TO USE AND PLACE IN AN ARCHITECTURAL CONTEXT.

JULES / armchair
ARCOLOR / small table





JULES / armchair



JIM / armchair
JULES / armchair



SIGMUND / bench
SIGMUND / small table

SIGMUND BY STUDIO ASAÏ

DEDICATA A FREUD E ISPIRATA ALLA LETTURA COME RIVELAZIONE DELL'IMMAGINAZIONE, LA COLLEZIONE SIGMUND SI COMPONE INIZIALMENTE DI DUE ELEMENTI: UN DAYBED E UNA PANCA. POI, COME VARIAZIONE SULLO STESSO TEMA, LA SUA ESTENSIONE DI DESIGN SI COMPLETA CON UNA SCRIVANIA E DEI TAVOLINI.
DEDICATED TO FREUD AND INSPIRED BY READING AS A REVELATION OF THE IMAGINATION, SIGMUND COLLECTION INITIALLY CONSISTS OF TWO PIECES OF FURNITURE: A DAYBED AND A BENCH. THEN AS A VARIATION ON THE SAME THEME, ITS DESIGN EXTENSION IS COMPLETED WITH A DESK AND SMALL TABLES.

SIGMUND / bench



SIGMUND / small table
STRIPS / sofa



SIGMUND / daybed



ELETTRA
BY B.B.P.R.

IL PRIMO GRANDE PROGETTO DI B.B.P.R. RISALE AL 1946, DOPO LA PARENTESI BELLICA E LA PIANIFICAZIONE DELLA RICOSTRUZIONE PER MILANO. ACCANTO AI MOBILI PER LA CASA, GLI ANNI '50 VEDONO ANCHE LA REALIZZAZIONE DEI PRIMI ARREDI PER UFFICI E SPAZI PUBBLICI, COME IL MODELLO ELETTRA.

B.B.P.R.'S FIRST MAJOR DESIGN PROJECT DATES BACK TO 1946, AFTER THE WAR INTERLUDE AND THE RECONSTRUCTION PLANNING FOR MILAN. ALONGSIDE FURNITURE FOR HOME, THE 1950S SAW ALSO THE CREATION OF THE FIRST FURNISHINGS FOR OFFICES AND PUBLIC SPACES, SUCH AS ELETTRA MODEL.

ELETTRA / chair





ELETTRA / chair
DIVA / screen - capsule collection Palmette 01



ELETTRA / chair

ORFEO / stool



ORFEO / stool - capsule collection Tiger 02



LIZZY
BY DAVID DOLCINI

LA PARTICOLARE COSTRUZIONE DELLA SEDIA, CON LE 4 GAMBE CHE SI INNESTANO SINGOLARMENTE NELLO SCHIENALE IN MASSELLO, NE AUMENTA LA RESISTENZA DELL'INTERA STRUTTURA, PERMETTENDO COSÌ UNA RIDUZIONE DELLE SEZIONI E QUINDI UN MINOR IMPIEGO DI MATERIALE. L'UTILIZZO DELLA CURVATURA AL VAPORE DEL LEGNO, COME PRINCIPALE TECNOLOGIA IMPIEGATA PER LA REALIZZAZIONE DEL PRODOTTO, CONSENTE DI RIDURRE AL MINIMO GLI SFRIDI DI LEGNO MASSELLO. LA STRUTTURA È IN LEGNO MASSELLO CURVATO DI FRASSINO, MENTRE LA SEDUTA È IN MULTISTRATO DI FAGGIO PLACCATO FRASSINO. THE UNIQUE CONSTRUCTION OF THE CHAIR, WITH THE 4 LEGS THAT ARE GRAFTED INDIVIDUALLY IN THE SOLID WOOD BACKREST, INCREASES THE STRENGTH OF THE ENTIRE STRUCTURE, ALLOWING A REDUCTION OF SECTIONS AND THEREFORE LESS USE OF MATERIAL. THE USE OF STEAM BENDING OF THE WOOD, AS THE MAIN TECHNIQUE APPLIED FOR THE CREATION OF THE PRODUCT, RESULTS IN THE MINIMIZATION OF THE WASTE OF SOLID WOOD. THE STRUCTURE IS IN SOLID BENDED ASH, WHILE THE SEAT IS IN MULTILAYER BEECH PLATED ASH.

LIZZY / chair





PONTI
BY CLAESSON KOIVISTO RUNE

ISPIRANDOSI ALL'ELEGANTE BELLEZZA DEI PONTI E ALLE OPERE DEL FAMOSO DESIGNER MILANESE OMONIMO, È STATO PROGETTATO UNO SCRITTOIO DALLE LINEE NETTE E ORDINATE, AL TEMPO STESSO RIGOROSE E SQUADRATE.

INSPIRED BY THE ELEGANT BEAUTY OF BRIDGES AND BY THE WORKS OF THE FAMOUS MILANESE DESIGNER WITH THE SAME NAME, A WRITING DESK WAS DESIGNED, HAVING CLEAR AND TIDY LINES, AT THE SAME TIME RIGOROUS AND SQUARED.

PONTI / writing desk
BOTOLO / armchair



PONTI / writing desk
BOTOLO / armchair





BEN BEN
BY CINI BOERI

RIPARTENDO DAL MODELLO BENGODI, DISEGNATO NEL 1974, CINI BOERI FU SCELTA DA ARFLEX PER CREARE UN SISTEMA DI SEDUTE COMPOSTO DA ELEMENTI CURVILINEI, SICURI CHE SAREBBE STATO GRADITO, OGGI COME ALLORA. IL DIVANO BEN BEN SI ADATTA PERFETTAMENTE AD AMBIENTI HOME E CONTRACT.

STARTING AGAIN FROM THE MODEL BENGODI, DESIGNED IN 1974, CINI BOERI WAS CHOSEN BY ARFLEX FOR CREATING A SEATING SYSTEM COMPOSED OF CURVED ELEMENTS, SURE THAT IT WOULD HAVE BEEN APPRECIATED, TODAY AS WELL AS THEN. BEN BEN SOFA CAN BE PERFECTLY USED BOTH FOR HOME AND CONTRACT ENVIRONMENTS.





BEN BEN / sofa composition B 6



BEN BEN / sofa composition B 6

BEN BEN / sofa composition B 3
ELETTRA / armchair
CAPILANO / small table





ALGON
BY LUCA NICHETTO

ALGON È STATO SVILUPPATO FONDENDO LA SEMPLICITÀ SCANDINAVA CON UNA TAPPEZZERIA TRAPUNTATA A MOTIVI GEOMETRICI. DISPONIBILE CON SCHIENALE BASSO, CHE HA UNA RIGOROSA FORMALITÀ, E CON SCHIENALE ALTO, CHE LASCIA UN SENSO DI PRIVACY, PERFETTO PER CONVERSAZIONI SILENZIOSE A TARDA NOTTE O UN MOMENTO SOLITARIO DI TREGUA. ALGON WAS DEVELOPED, MELDING SCANDINAVIAN SIMPLICITY WITH A PATTERNED QUILTED UPHOLSTERY. AVAILABLE WITH LOW BACKREST, THAT HAS A STRICT FORMALITY AND WITH HIGH BACKREST, THAT ALLOWS A SENSE OF PRIVACY, PERFECT FOR HUSHED LATE-NIGHT CONVERSATIONS OR A SOLITARY MOMENT OF RESPITE.

ALGON / armchair
BONSAI / sofa
TABLET / small table

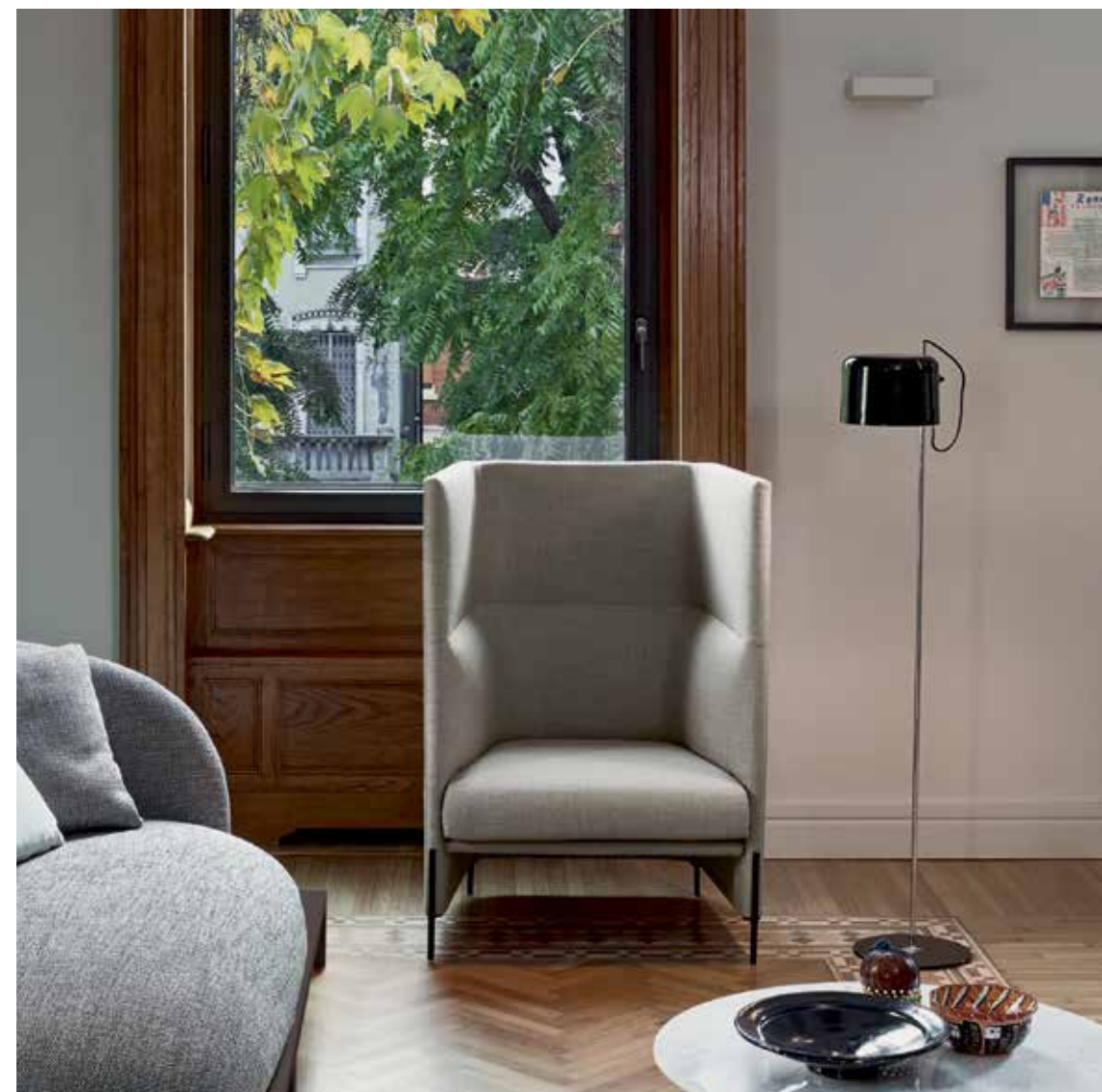



ALGON / armchair
ARCOLOR / small table





BONSAI
BY CLAESSON KOIVISTO RUNE

LA COLLEZIONE DI SEDUTE BONSAI SI ISPIRA ALLE RIFLESSIONI SULL'ESTETICA E SULLA CULTURA GIAPPONESE. I SEDILI SONO CARATTERIZZATI DA LINEE MORBIDE E CURVE. QUESTE FORME INVITANTI E AMICHEVOLI RICORDANO I CESPUGLI E GLI ARBUSTI DEI GIARDINI DI TUTTO IL GIAPPONE, CHE SONO STATI COLTIVATI E TAGLIATI PER CREARE FORME BELLE, MORBIDE, "ORGANICHE", SIMILI A NUVOLE.
BONSAI SEATING COLLECTION IS INSPIRED BY REFLECTIONS UPON JAPANESE AESTHETICS AND CULTURE. THE SEATS ARE CHARACTERISED BY SOFT AND CURVED FORMS. THESE INVITING, FRIENDLY SHAPES ARE REMINISCENT OF THE BUSHES AND SHRUBS, FOUND IN GARDENS ALL OVER JAPAN, THAT HAVE BEEN CULTIVATED AND TRIMMED IN ORDER TO CREATE BEAUTIFUL, SOFT, 'ORGANIC', CLOUD-LIKE SHAPES.

BONSAI / sofa
CICLOPE / mirror
ARCOLOR / small table



BONSAI / sofa
TABLET / small table
ALGON / armchair



BONSAI / sofa
TABLET / small table
NEPTUNIA / chair





RENDEZ-VOUS

BY MAURO LIPPARINI

SERENITÀ, SEMPLICITÀ, MODULARITÀ SONO ALCUNE DELLE PAROLE CHIAVE DI RENDEZ-VOUS. IL SUO GENERALE RIGORE FORMALE È ACCOMPAGNATO DALL'ESUBERANZA DELLA MORBIDEZZA INTERIORE, COME IL TENTATIVO DI ABBRACCIARE E TRATTENERE IL CORPO E IL PIACERE DEL COMFORT. SERENITY, SIMPLICITY, MODULARITY ARE SOME OF THE KEY WORDS OF RENDEZ-VOUS. ITS OVERALL FORMAL RIGOR IS ACCOMPANIED BY THE EXUBERANCE OF THE INNER SOFTNESS, AS TRYING TO HUG AND HOLD THE BODY AND THE PLEASURE OF COMFORT.

RENDEZ-VOUS / sofa
TABLET / small table
GIULIETTA / armchair





RENDEZ-VOUS / sofa composition R 15
HALL / armchair
TABLET / small table



CLAUDINE

BY CLAESSION KOIVISTO RUNE

UNA TIPOLOGIA CLASSICA SERVITA SU UN DOLCE VASSOIO, IL DIVANO HA UNA CONFIGURAZIONE FLESSIBILE - ALTO, BASSO, PICCOLO, GRANDE, A DUE POSTI, TRE POSTI, POUF - SEMPRE SOSPESO SU UN BORDO ROVESCIATO, CHE RICORDA IL COLLETTO DELL'ABITO, NOTO IN FRANCESE COME "COL CLAUDINE".

A CLASSIC TYPOLOGY SERVED ON A TENDER TRAY, THE SOFA IS FLEXIBLE IN CONFIGURATION - HIGH, LOW, SMALL, BIG, TWO-SEATER, THREE-SEATER, POUF - ALWAYS FLOATING ON AN UPTURNED EDGE, REMINISCENT OF THE DRESS COLLAR KNOWN IN FRENCH AS "COL CLAUDINE".

CLAUDINE / sofa



CLAUDINE / sofa
CRADLE / small table
PECORELLE / armchair





K2
BY CARLO COLOMBO

UN SISTEMA DI SEDUTE DI GRANDE FORMATO E DI PARTICOLARE COMFORT. ISPIRATO ALLE ALTE VETTE, MA CARATTERIZZATO DA UNA GRANDE ELEGANZA FORMALE, SI ADATTA CON STILE ED ELEGANZA A TUTTI GLI SPAZI.

A SEATING SYSTEM OF LARGE FORMAT AND PARTICULAR COMFORT. INSPIRED BY THE HIGH PEAKS, BUT CHARACTERISED BY GREAT FORMAL ELEGANCE, IT ADAPTS WITH STYLE AND ELEGANCE TO ALL SPACES.

K2 / sofa composition K 02



K2 / sofa composition K 02
GIULIETTA / armchair
DELFINO / pouf





K2 / sofa composition K 03



K2 Extra / sofa



**K2 Extra / sofa
composition KE 03**



GIULIETTA BY B.B.P.R.

IL DESIGN DEGLI ANNI '50 NASCE IN UN MOMENTO IN CUI L'ITALIA VOLEVA IL RISCATTO DOPO LA GUERRA. GLI ARCHITETTI (NON ANCORA CHIAMATI DESIGNER) E LE AZIENDE HANNO CREATO PRODOTTI PER TRASMETTERE SPERANZA E BUON UMORE NELLE PERSONE. LO STUDIO B.B.P.R. HA DISEGNATO LA POLTRONA GIULIETTA, CON TUTTE LE CARATTERISTICHE DELLA PRODUZIONE ARFLEX: STUDIO APPROFONDITO DELLA LINEA E COMFORT ASSOLUTO, SENZA DIMENTICARE L'ELEGANZA.

THE 50-YEARS DESIGN WAS BORN AT A TIME WHEN ITALY WANTED REDEMPTION AFTER THE WAR. THE ARCHITECTS (NOT YET CALLED DESIGNER) AND THE COMPANIES CREATED PRODUCTS TO INSPIRE HOPE AND GOOD HUMOUR TO PEOPLE. B.B.P.R. OFFICE DESIGNED THE ARMCHAIR GIULIETTA, WITH ALL THE CHARACTERISTICS OF ARFLEX PRODUCTION: DEEP STUDY OF THE LINE AND ABSOLUTE COMFORT, WITHOUT FORGETTING THE ELEGANCE.

GIULIETTA / armchair
TABLET / small table





GIULIETTA / armchair
BONSAI / small table





FRAME / sofa
composition F 9
TABLET / small table



FAUBOURG / sofa





KATRIN
BY CARLO COLOMBO

LA CONTINUA RICERCA DELL'ELEGANZA E DELLA SEMPLICITA' HA PORTATO L'ARCHITETTO CARLO COLOMBO ALLA REALIZZAZIONE DELLA POLTRONA KATRIN, CONCEPITA COME UN CORPO DA VESTIRE CON UN ACCURATO E LUSSUOSO ABITO.
THE CONTINUOUS SEARCH FOR ELEGANCE AND SIMPLICITY HAS BROUGHT THE ARCHITECT CARLO COLOMBO TO THE REALIZATION OF KATRIN ARMCHAIR, CONCEIVED AS A BODY TO BE DRESSED WITH AN ELEGANT AND LUXURIOUS DRESS.







PALAZZO
BY BERNHARDT & VELLA

IL LETTO PALAZZO È RITMATO DAL GIOCO DI PANNELLI DI DIVERSE DIMENSIONI, CHE POSSONO ACCOGLIERE IL SOMMIER, CREANDO UN PIACEVOLE SENSO DI INTIMITÀ E REALIZZANDO UN LETTO PRATICO E MOLTO ELEGANTE, ADATTO SIA ALL'AMBIENTE RESIDENZIALE CHE ALL'HOSPITALITY.
PALAZZO BED IS RHYTHMED BY THE PLAY OF PANELS OF DIFFERENT SIZES, WHICH CAN ACCOMMODATE THE BASE, CREATING A PLEASANT SENSE OF INTIMACY AND REALIZING A PRACTICAL AND VERY ELEGANT BED, SUITABLE FOR BOTH RESIDENTIAL AND HOSPITALITY.

PALAZZO / bed
PONTI / writing desk
NEPTUNIA / chair
SIGMUND / bench



**PALAZZO / bed -
capsule collection
Line 6 category T6
SIGMUND / bench**



SUITE / bed





STRIPS BY CINI BOERI

IL DIVANO COMPONENTE STRIPS, CHE APPARTIENE ALLA STORIA DI ARFLEX, È SICURAMENTE UNO DEI PRODOTTI PIÙ FAMOSI. IL MODELLO È CARATTERIZZATO DA UNA FODERA TRAPUNTATA, COMPLETAMENTE SFODERABILE, DISPONIBILE ANCHE NELLA VERSIONE LETTO. L'ARCH. CINI BOERI HA SEMPRE CERCATO DI REALIZZARE IDEE INNOVATIVE, IN MODO DA POTER MIGLIORARE LA QUALITÀ DELLA VITA E ANCHE I MATERIALI UTILIZZATI ERANO RIVOLUZIONARI PER IL SETTORE DEL MOBILE. QUESTA IDEA È STATA APPLICATA SOPRATTUTTO ALLO STRIPS LETTO, DOVE IL RIVESTIMENTO DIVENTA PARTE INTEGRANTE DEL LETTO: CON UNA SEMPLICE CERNIERA, IL LETTO VIENE COPERTO E RIFATTO, AGGIUNGENDO SOLTANTO IL CUSCINO.

THE MODULAR SOFA STRIPS, WHICH BELONGS TO THE HISTORY OF ARFLEX, IS REALLY ONE OF THE MOST FAMOUS PRODUCTS. THE MAIN CHARACTERISTIC OF THE MODEL IS THE REMOVABLE QUILTED COVER, AVAILABLE ALSO IN THE VERSION BED.

ARCH. CINI BOERI ALWAYS TRIED TO REALIZE INNOVATIVE IDEAS, TO IMPROVE THE QUALITY OF LIFE AND ALSO THE USED MATERIALS WERE REVOLUTIONARY FOR THE FURNITURE MARKET. THIS IDEA WAS APPLIED MOST OF ALL TO THE STRIPS BED, WHERE THE COVER BECOMES PART OF THE BED ITSELF: BY OPENING A SIMPLE ZIP, THE BED IS READY AND ONLY A PILLOW MUST BE ADDED.

STRIPS / bed
BOTOLO / armchair





MARENCO OUTDOOR BY MARIO MARENCO

ARFLEX, PER CELEBRARE IL GRANDE SUCCESSO DEL MODELLO MARENCO, CHE DURA DA 52 ANNI, HA PENSATO DI REALIZZARE LA VERSIONE OUTDOOR. LA MORBIDEZZA SCULTOREA, CHE CONTRADDISTINGUE DA SEMPRE IL SUO DESIGN INCONFONDIBILE, È DISPONIBILE ORA ANCHE PER L'ESTERNO, PER ARREDARE TERRAZZE E VERANDE DI QUALSIASI DIMENSIONE, CON STILE ED ELEGANZA.

ARFLEX, TO CELEBRATE THE GREAT 52-YEARS SUCCESS OF MARENCO MODEL, THOUGHT TO "MOVE IT OUTSIDE", PRESENTING THE OUTDOOR VERSION. SCULPTURAL SOFTNESS, WHICH MARKS SINCE ALWAYS ITS UNIQUE DESIGN, IS NOW AVAILABLE ALSO FOR OUTDOOR, TO FURNISH TERRACES AND VERANDAS OF ANY DIMENSIONS WITH STYLE AND ELEGANCE.

**MARENCO OUTDOOR / armchair –
capsule collection Riga 004 category T6**



MARENCO OUTDOOR / pouf



306 / design collection

MARENCO OUTDOOR / armchair



307 / design collection

MARENCO OUTDOOR / armchair –
capsule collection Riga 003 category T6



MARENCO OUTDOOR / sofa
MARENCO OUTDOOR / armchair
MARENCO OUTDOOR / pouf





310 / design collection



TABOGA OUTDOOR / armchair

311 / design collection

arflex COLLECTION
TECHNICAL DRAWINGS



9000

Poltrona
Armchair

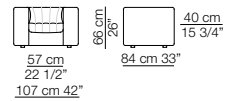

Pouf

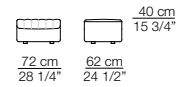

**Composizioni
Compositions**

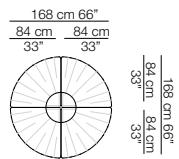

NV 02

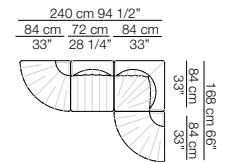

NV 06

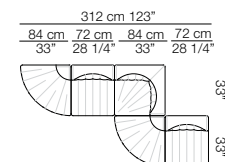

NV 09

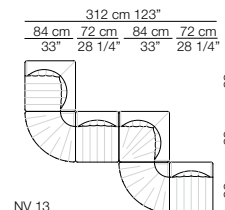

NV 13

Divani
Sofas

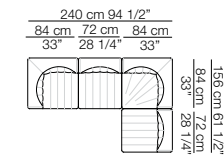
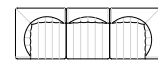
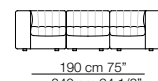
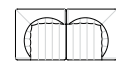
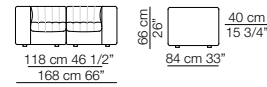

NV 03

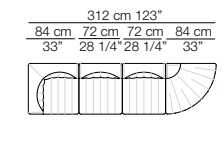

NV 07

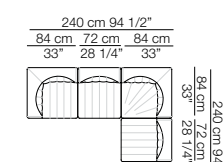

NV 10

Elemento con 1 bracciolo
Unit with 1 armrest

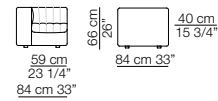

Elemento angolo
Corner unit

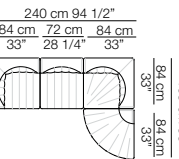
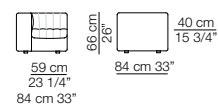

NV 04

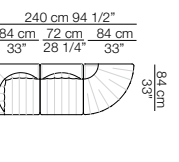

NV 07-B

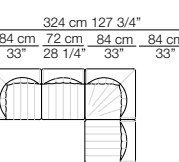

NV 11

Elemento senza braccioli
Unit without armrests

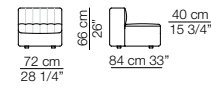

Elemento curvo
Curved unit

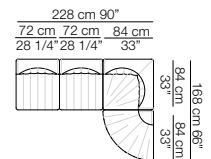
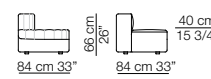

NV 05

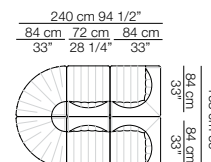

NV 08

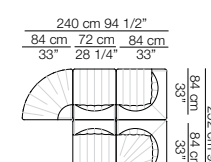

NV 12

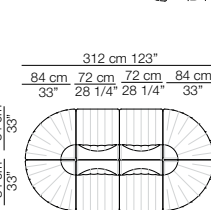

NV 14



Arcolor

Divani
Sofas

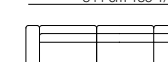
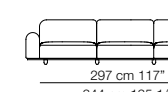
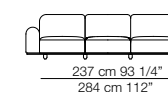
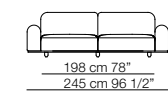
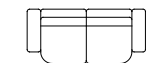
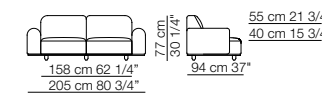

Tavolino angolare
Corner small table

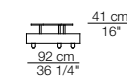

**Composizioni
Compositions**

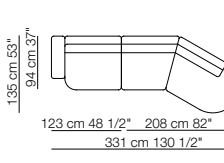

AR 02

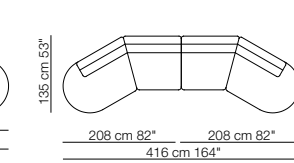

AR 03

Elementi con 1 bracciolo
Units with 1 armrest

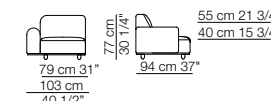

Elemento angolo
Corner unit

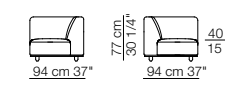

Divani trapezio
Trapezoid sofas

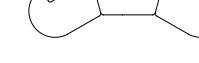
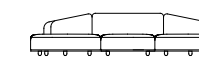
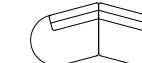
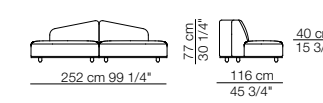

Elementi senza braccioli
Units without armrests

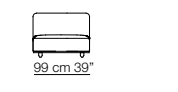
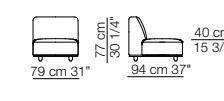

Pouf

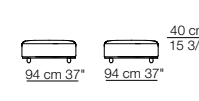

Pouf per elementi isola
Pouf for isle units

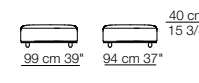
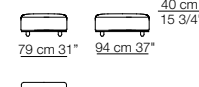

Elementi isola trapezio
Trapezoid isle units

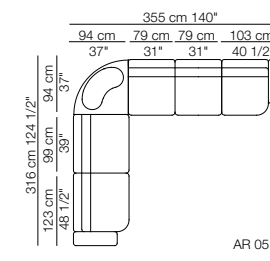
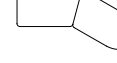
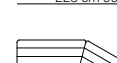
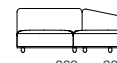
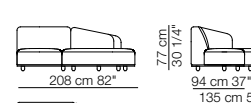

AR 05

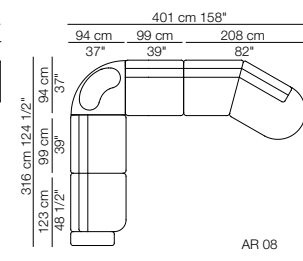

AR 08



Ben Ben

Divano
Sofa

Elementi con 1 bracciolo
Units with 1 armrest

Elemento senza braccioli
Unit without armrests

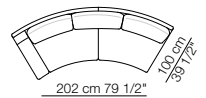
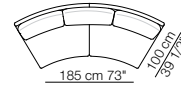
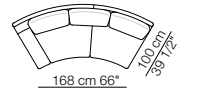
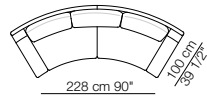
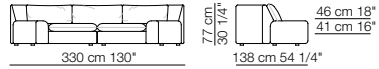

**Composizioni
Compositions**

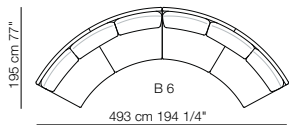
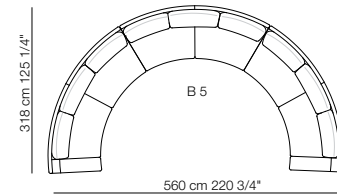
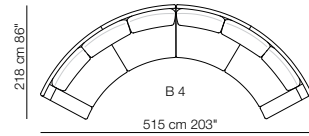
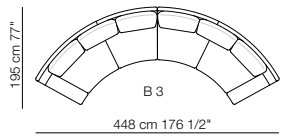

Bobo

Divano
Sofa

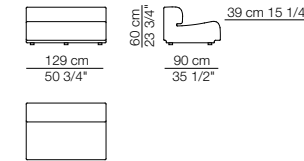

Bonsai

Divano con piedini in metallo
Sofa with metal feet

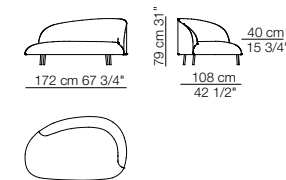

Divano con base in legno
Sofa with wooden base

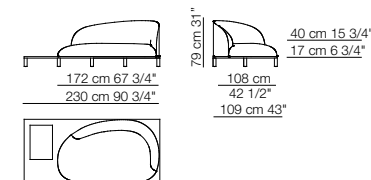

Tavolino
Small table

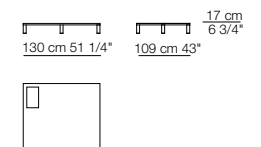

Casablanca

Divani
Sofas

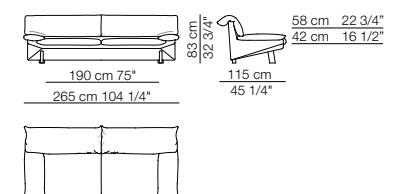
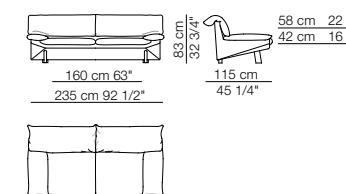
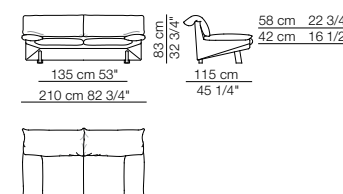



Claudine M

Divani
Sofas

Elementi con 1 bracciolo
Units with 1 armrest

Elementi senza braccioli
Units without armrests

Chaise longue con 1 bracciolo
Chaise longue with 1 armrest

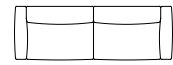
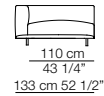
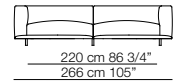
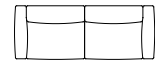
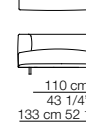
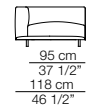
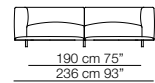
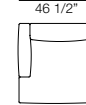
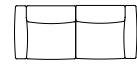
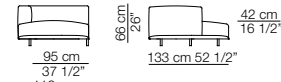
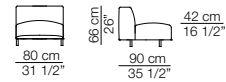
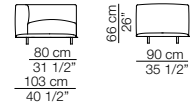
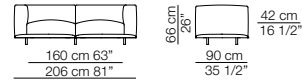

Pouf

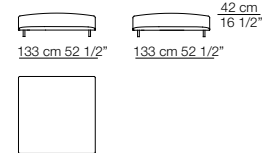
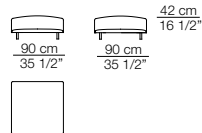

Elemento angolo
Corner unit

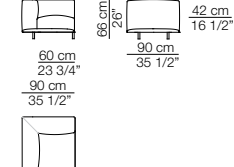

Claudine L

Divani
Sofas

Elementi con 1 bracciolo
Units with 1 armrest

Elementi senza braccioli
Units without armrests

Chaise longue con 1 bracciolo
Chaise longue with 1 armrest

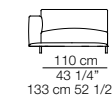
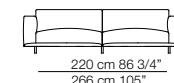
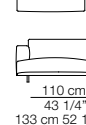
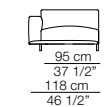
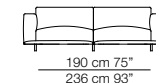
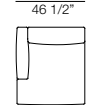
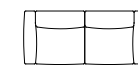
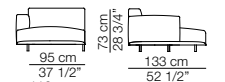
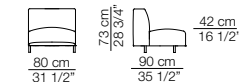
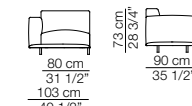
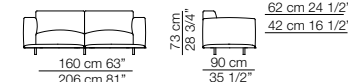

Elemento angolo
Corner unit

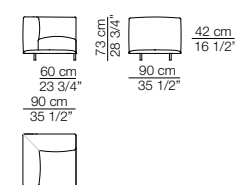

Pouf

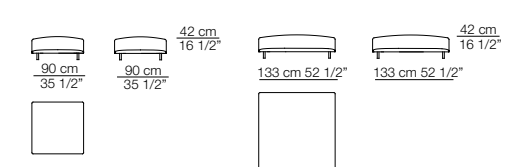

Claudine M-L

Composizioni
Compositions

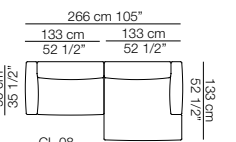
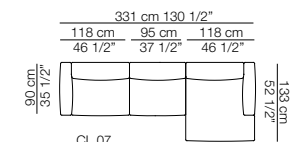
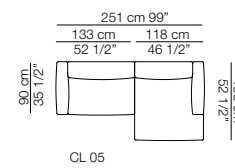
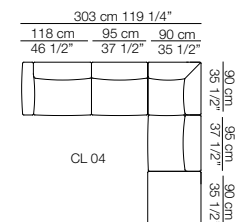



Cousy

Poltrona
Armchair

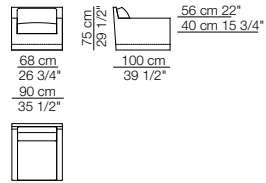

Chaise longue con 2 braccioli
Chaise longue with 2 armrests

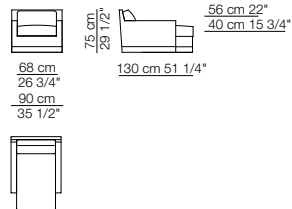

Pouf

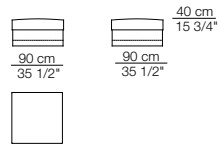

Cradle

Divano
Sofa

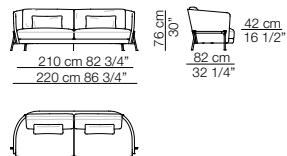

Divani
Sofas

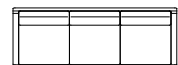
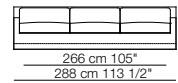
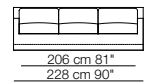
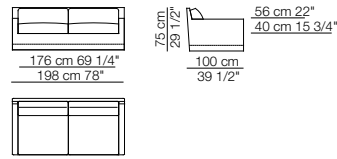

Service

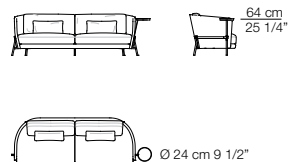

Faubourg

Divani
Sofas

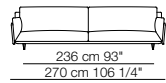
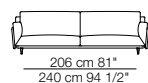
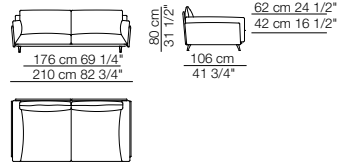

Cuscini Faubourg
Faubourg cushions

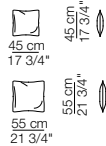

Deep Cradle

Divano
Sofa

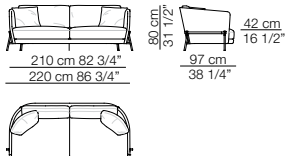

Edo

Divani P.106
Sofas D.106

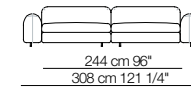
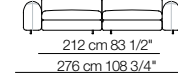
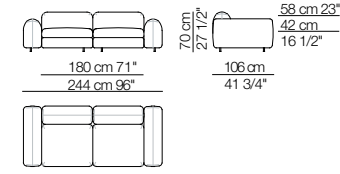

Elementi senza braccioli P.122
Units without armrests D.122



Elementi con 1 bracciolo P.106
Units with 1 armrest D.106

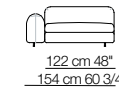
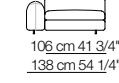
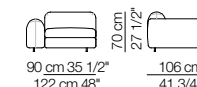

Elementi senza braccioli P.138
Units without armrests D.138

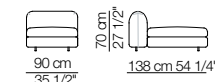

Elementi con 1 bracciolo P.122
Units with 1 armrest D.122

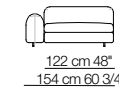
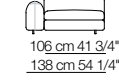
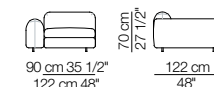

Elementi angolo P.106
Corner units D.106

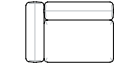
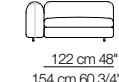
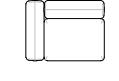
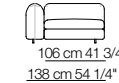
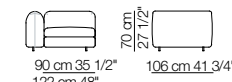

Elementi senza braccioli P.106
Units without armrests D.106

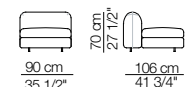

Elementi angolo P.122
Corner units D.122

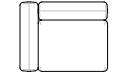
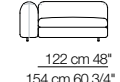
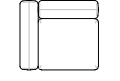
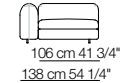
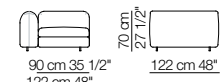

Composizioni
Compositions

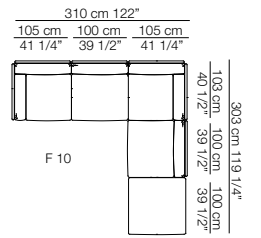
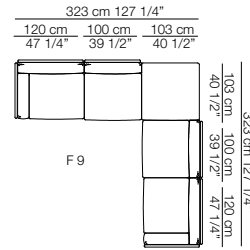
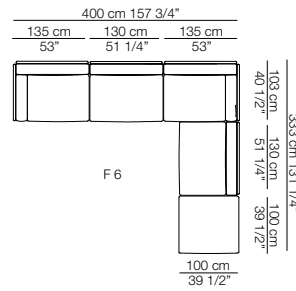
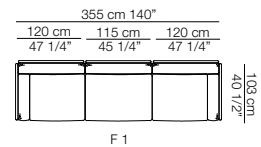

Hall
Divano
Sofa

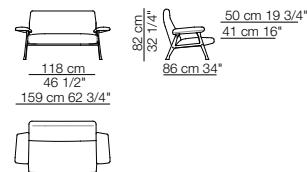

Hug love seat
Divano con schienale basso
Sofa with low backrest

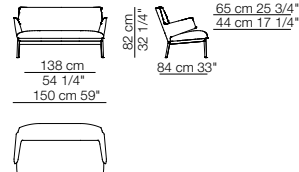

Hug love seat
Divano con schienale alto
Sofa with high backrest

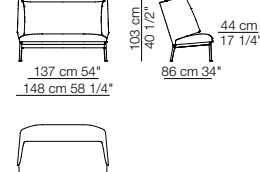

K2

Divani
Sofas

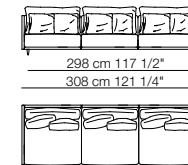
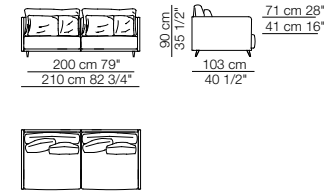

Elemento con 1 bracciolo
Unit with 1 armrest

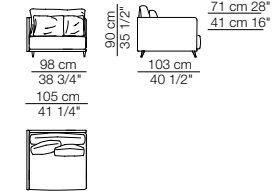

Elemento senza braccioli
Unit without armrests

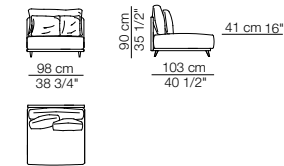

Elemento angolo
Corner unit

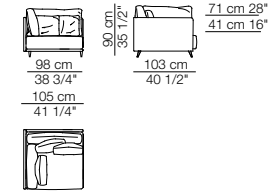

Pouf

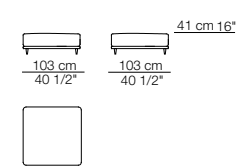

Cuscini
Cushions

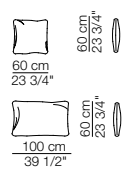

Composizioni
Compositions

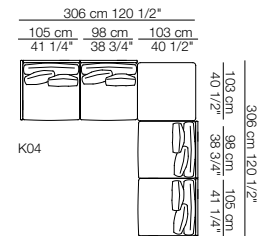
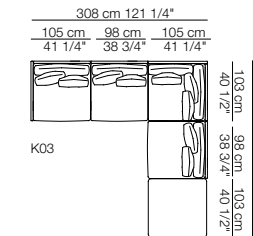
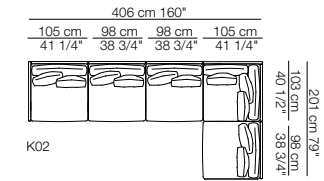



K2 Extra

Divani
Sofas

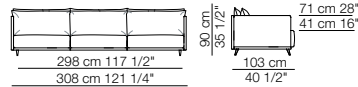
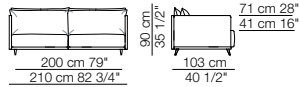

Elemento con 1 bracciolo
Unit with 1 armrest

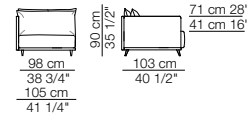

Elemento angolo
Corner unit

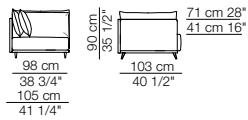

Elemento senza braccioli
Unit without armrests

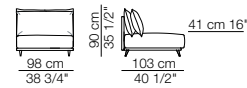

Pouf

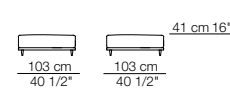

Composizioni
Compositions

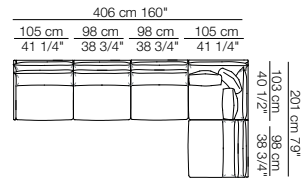

KE 02

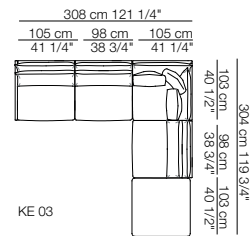

KE 03

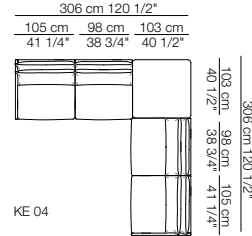

KE 04

Sofa with standard armrests
Divano con braccioli standard



24 cm
9 1/2"

Sofa with thin armrests - version "T"
Divano con braccioli stretti - versione "T"



14 cm
5 1/2"

Leenus

Divani
Sofas

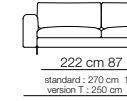
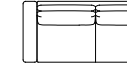
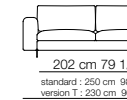
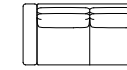
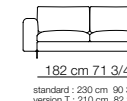
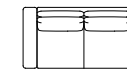
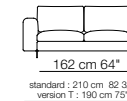
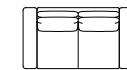
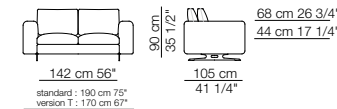

Elementi con 1 bracciolo
Units with 1 armrest

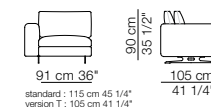

Elementi con 1 bracciolo
Units with 1 armrest

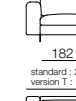
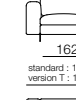
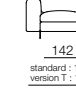
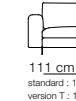
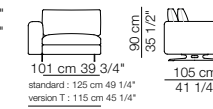

Elementi con 1 bracciolo
Units with 1 armrest

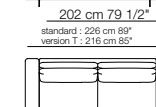

Elementi con 1 bracciolo
Units with 1 armrest

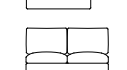
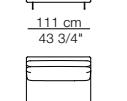
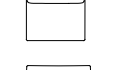
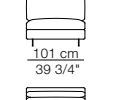
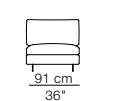
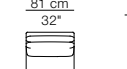
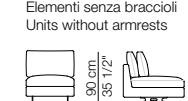
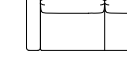
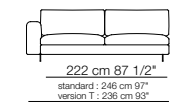

Elementi con 1 bracciolo
Units with 1 armrest

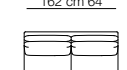
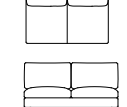

Elementi senza braccioli
Units without armrests

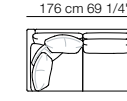
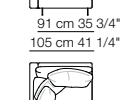
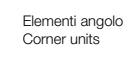
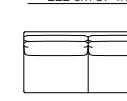
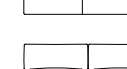
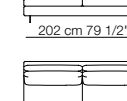
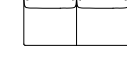
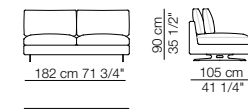

Elementi angolo
Corner units

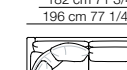
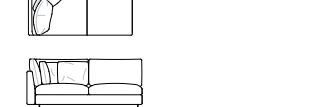

Divani / Sofas

**Elementi angolo
Corner units**

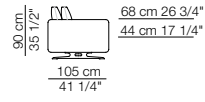
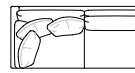
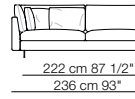
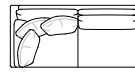
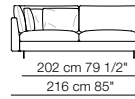
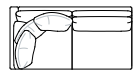
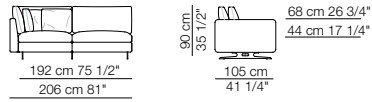

**Elementi isola con angolo
Isle units with corner unit**

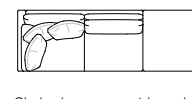
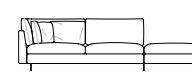
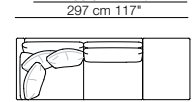
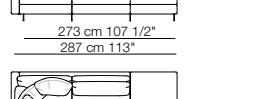
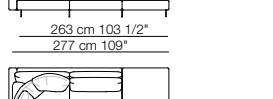
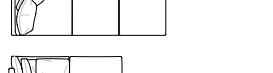
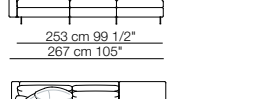
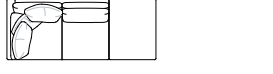
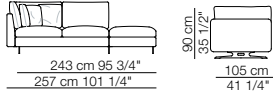

**Chaise longue con 1 bracciolo
Chaise longue with 1 armrest**

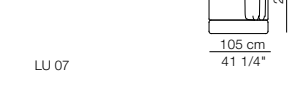
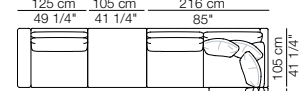
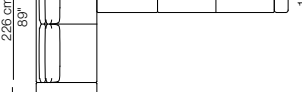
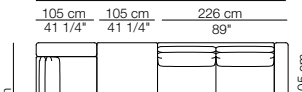
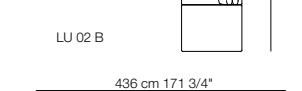
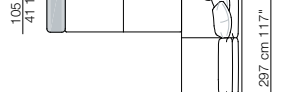
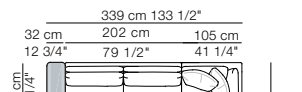
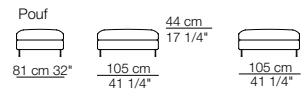
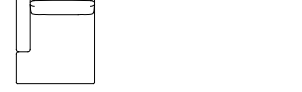
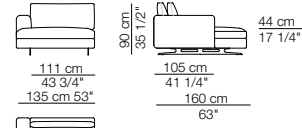

Divani / Sofas



Marechiaro

**Poltrone con braccioli bassi
Armchairs with low armrests**

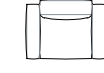
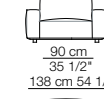
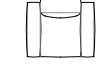
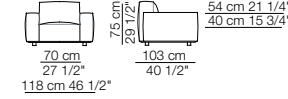

**Poltrona con braccioli alti
Armchair with high armrests**

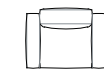
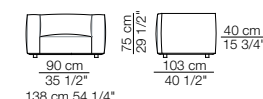

**Elementi senza braccioli
Units without armrests**

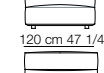
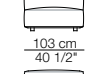
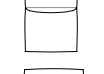
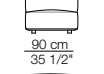
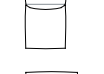
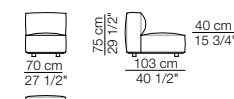

**Divani
Sofas**

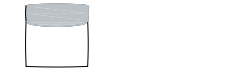
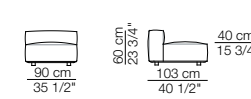
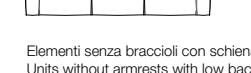
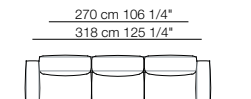
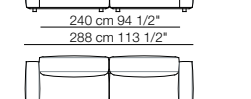
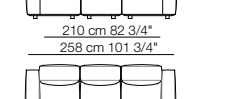
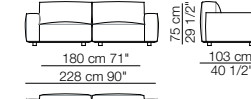

**Elementi con 1 bracciolo
Units with 1 armrest**

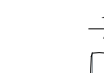
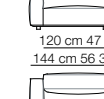
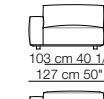
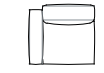
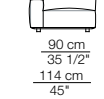
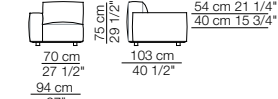

**Elementi con 1 bracciolo alto
Units with 1 high armrest**

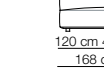
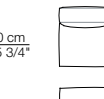
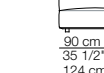
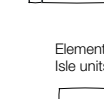
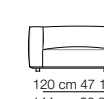
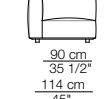
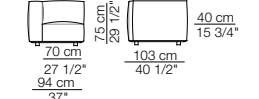

**Composizioni
Compositions**

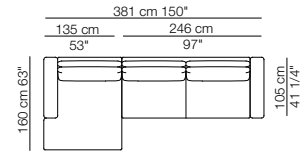

LU 01

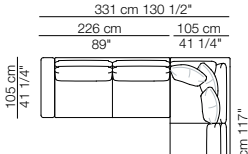

LU 02

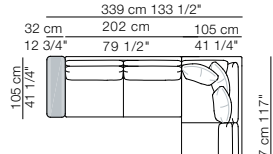

LU 02 B

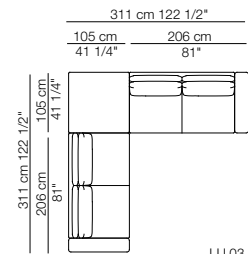

LU 03

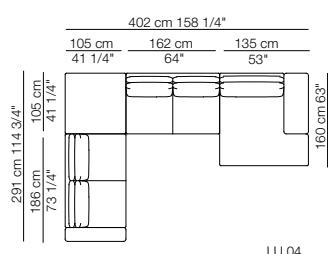

LU 04

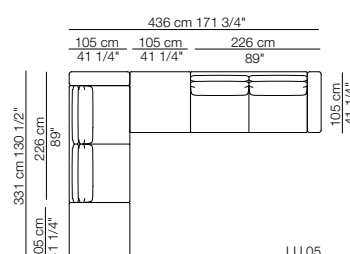

LU 05

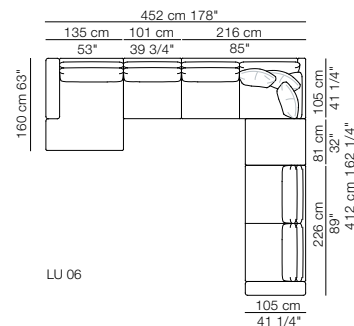

LU 06

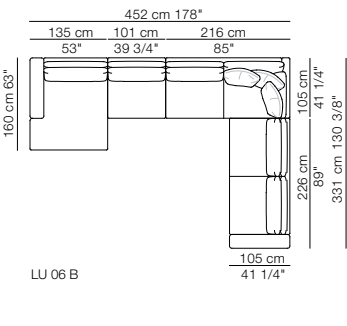

LU 06 B

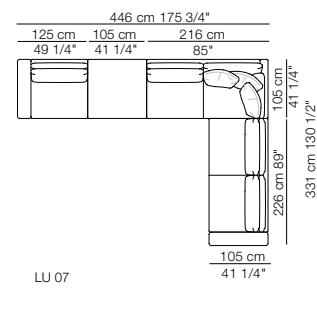

LU 07



Elementi con 1 bracciolo P.120
Units with 1 armrest D.120

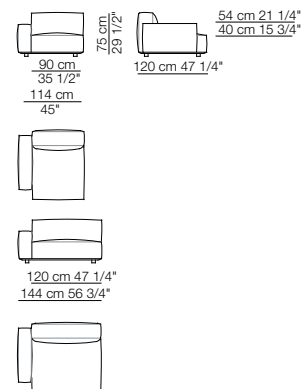

Elementi senza braccioli P.120
Units without armrests D.120

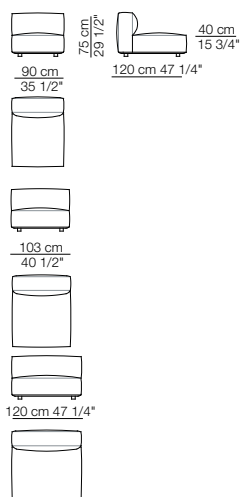

Elementi angolo P.120
Corner units D.120

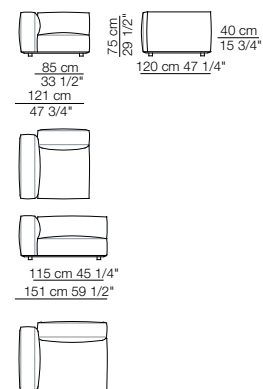

Elementi con 1 bracciolo lungo P.120
Units with 1 long armrest D.120

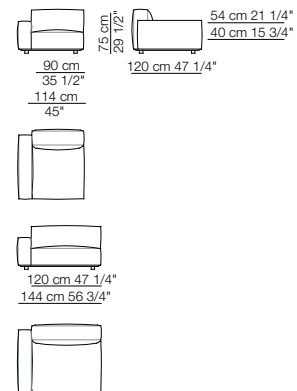

Elementi senza braccioli con schienale basso P.120
Units without armrests with low backrest D.120

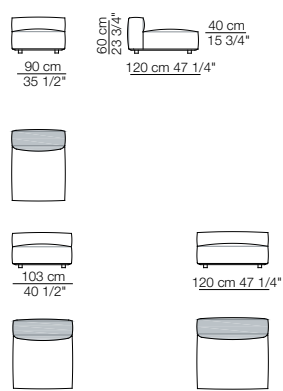

Pouf

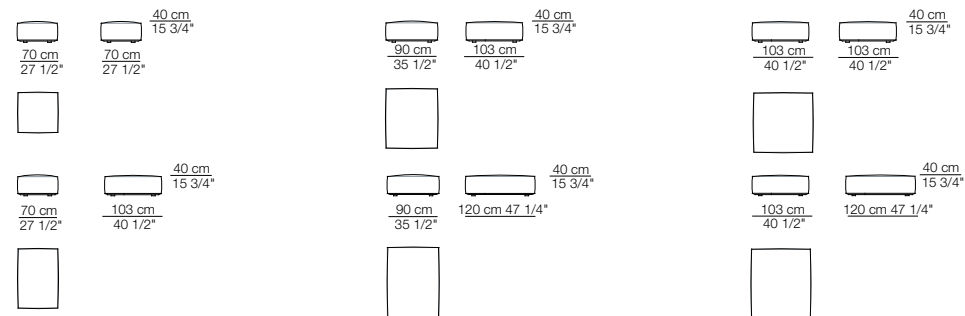

Composizioni
Compositions

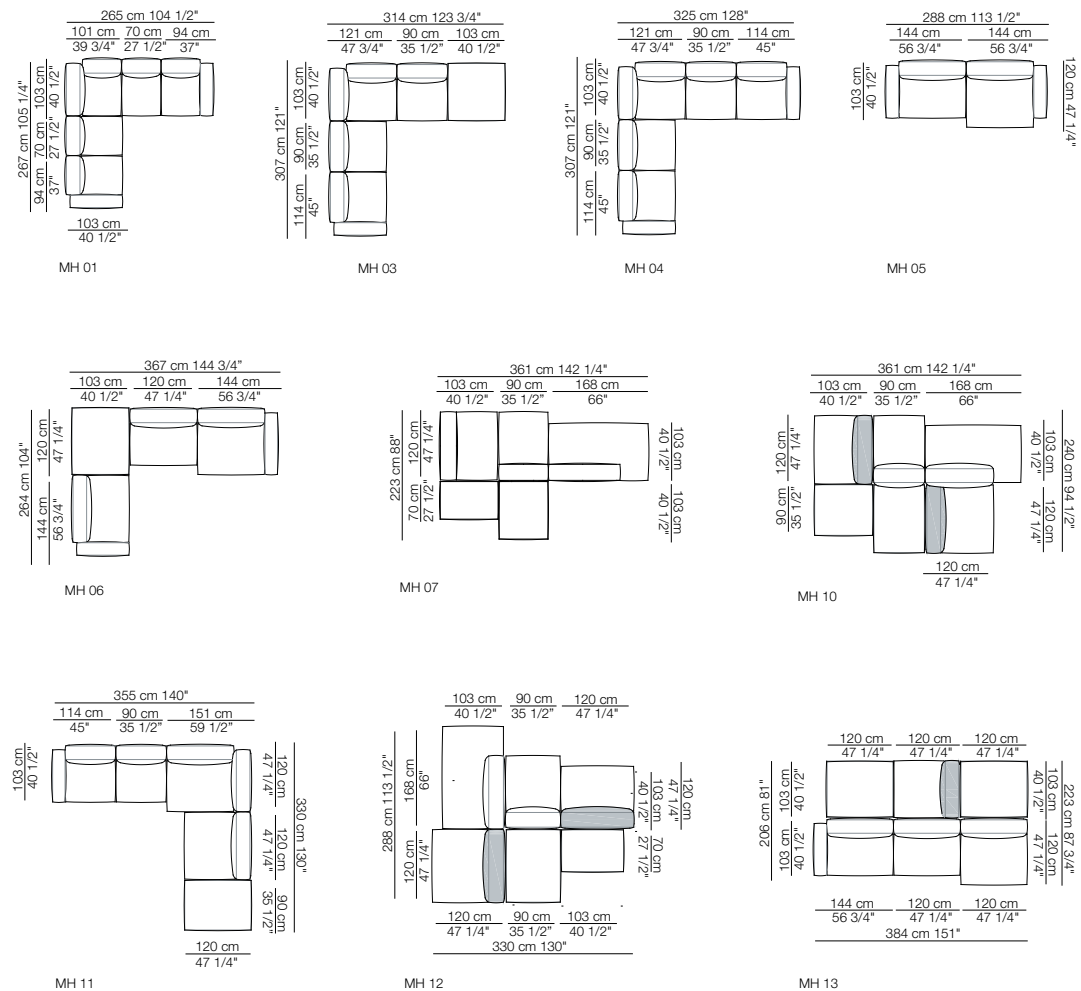



Marengo

Poltrone senza braccioli
Armchairs without armrests

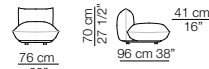

Poltrona con 2 braccioli
Armchair with 2 armrests

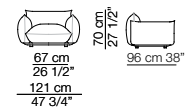

Divani
Sofas

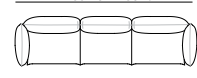
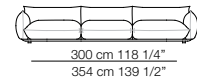
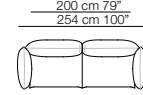
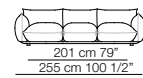
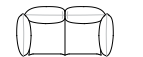
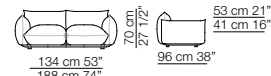

Elementi con 1 bracciolo
Units with 1 armrest

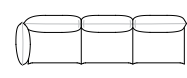
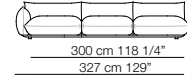
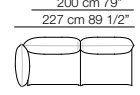
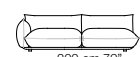
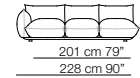
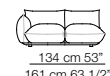

Elementi senza braccioli
Units without armrests

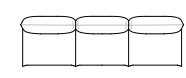
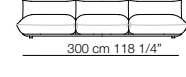
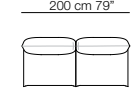
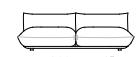
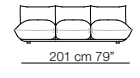
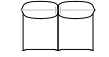
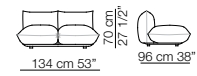

Pouf

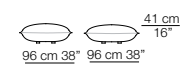
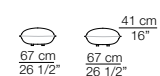

Elementi angolo
Corner units

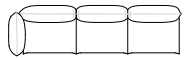
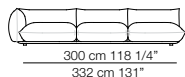
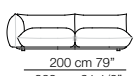
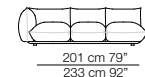
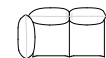

Elementi angolo con 1 bracciolo
Corner units with 1 armrest



Elementi isola con angolo
Isle units with corner unit

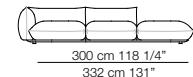
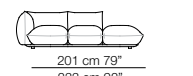

Composizioni
Compositions

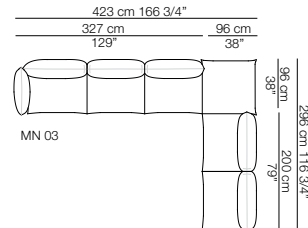
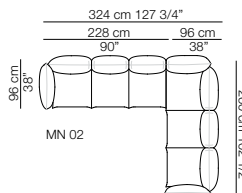
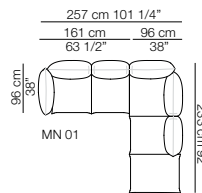

Naviglio

Divani
Sofas

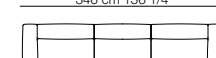
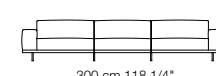
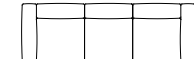
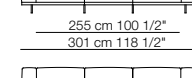
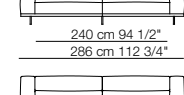
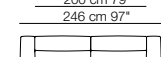
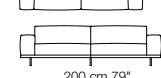
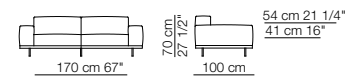

Pouf

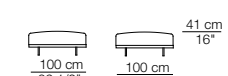



Pecorelle

Divano
Sofa

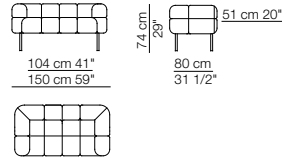

Rendez-vous D.95

Divani
Sofas

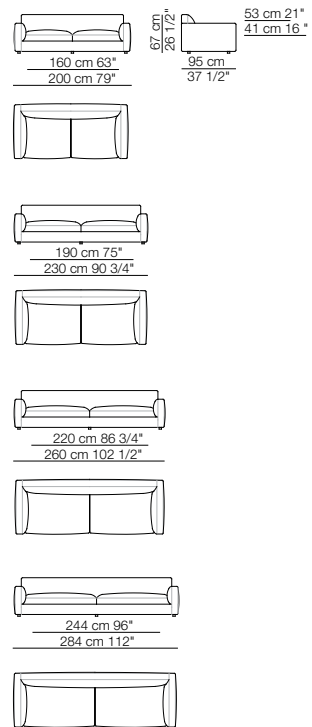

Divani con braccioli alti
Sofas with high armrests

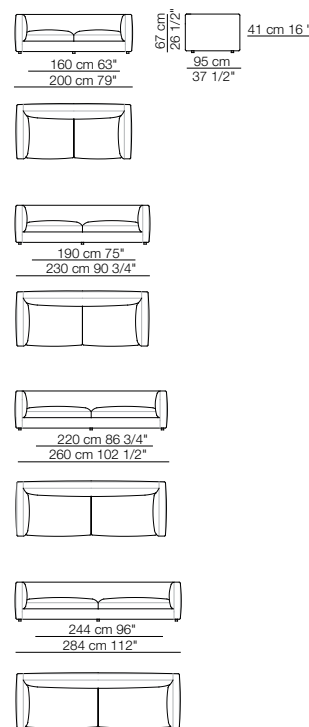

Elementi con 1 bracciolo
Units with 1 armrest

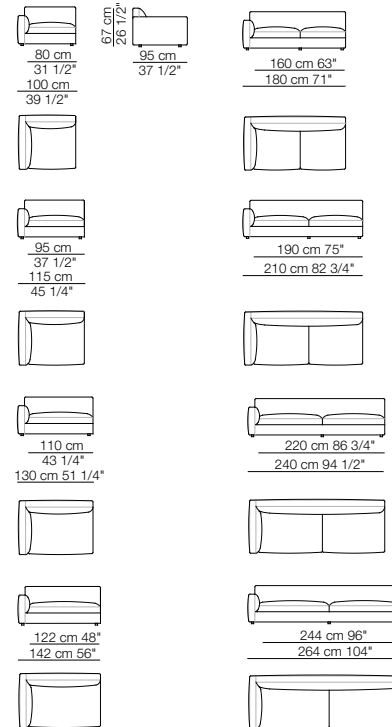

Elementi angolo / Elementi con 1 bracciolo alto
Corner units / Units with 1 high armrest

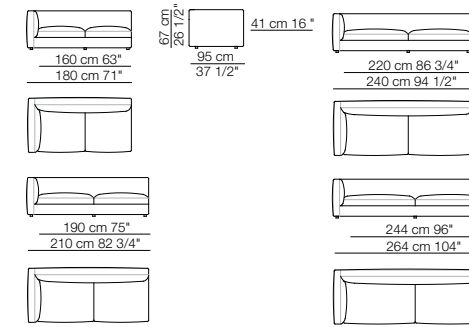

Elementi angolo con 1 bracciolo
Corner units with 1 armrest

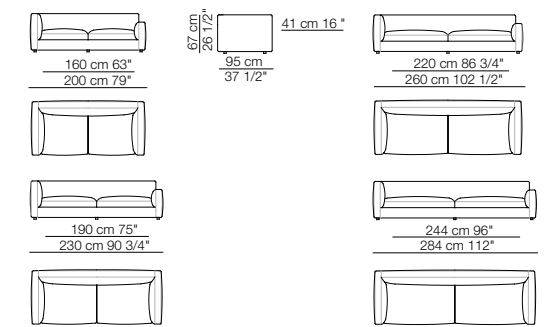

Elementi senza braccioli
Units without armrests

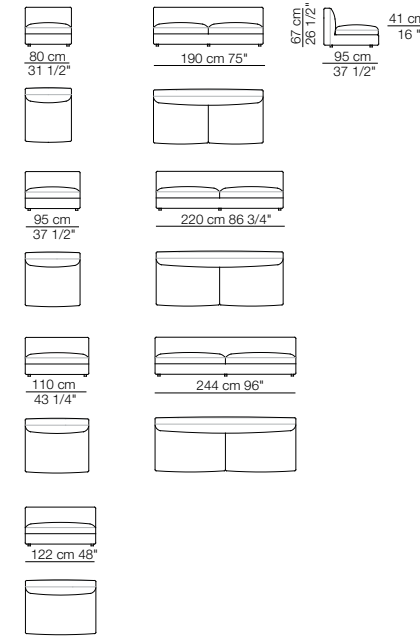

Elementi isola senza braccioli
Isle units without armrests

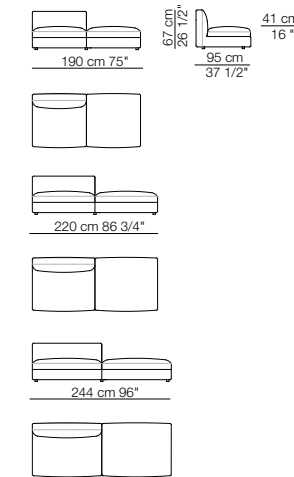

Elementi isola con angolo
Isle units with corner unit

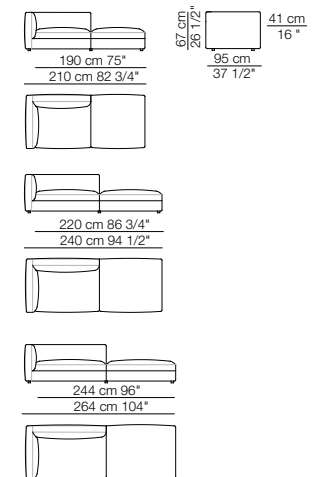

Pouf

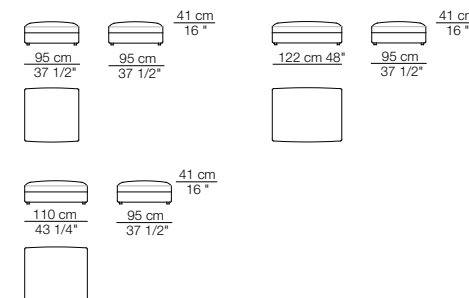

Cuscini schienale opzionali
Optional backrest cushions

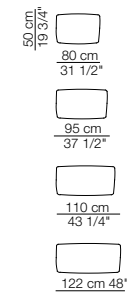

Cuscini schienale angolo
Backrest corner cushions

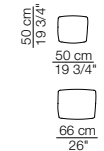



Rendez-vous D.120

Divani Sofas

Divani con braccioli alti Sofas with high armrests

Elementi angolo con 1 bracciolo Corner units with 1 armrest

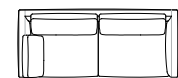
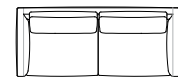
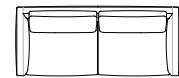
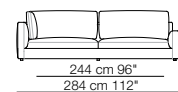
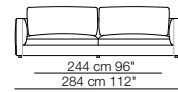
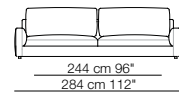
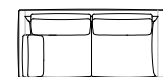
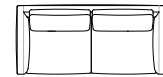
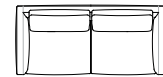
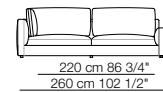
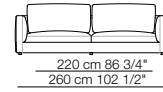
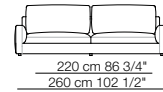
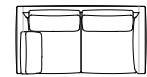
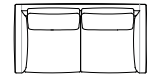
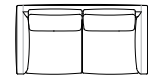
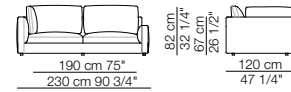
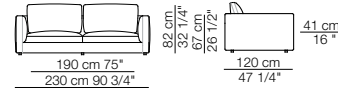
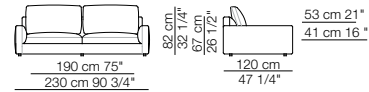

Elementi con 1 bracciolo Units with 1 armrest

Elementi angolo / Elementi con 1 bracciolo alto Corner units / Units with 1 high armrest

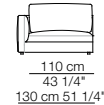
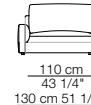
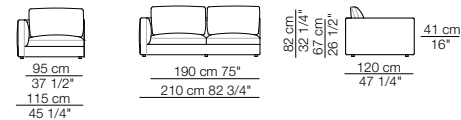
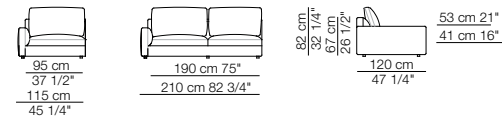

Elementi senza braccioli Units without armrests

Elementi isola senza braccioli Isle units without armrests

Elementi isola con angolo Isle units with corner unit

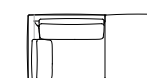
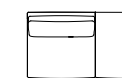
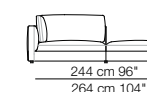
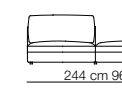
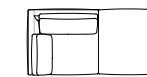
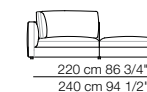
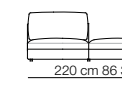
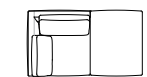
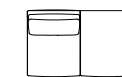
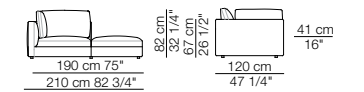
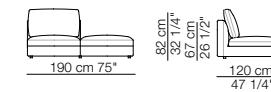
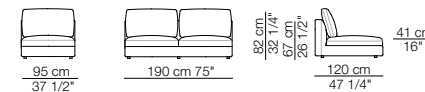

Pouf

Cuscino schienale per angolo Backrest cushion for corner unit

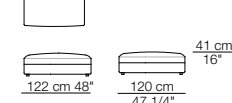
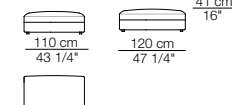
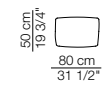
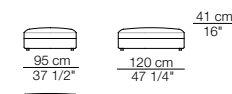

Rendez-vous D.95 - 120

Composizioni
Compositions

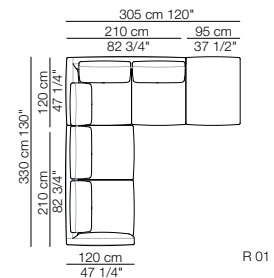

R 01

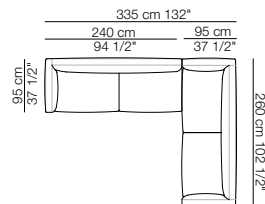

R 03

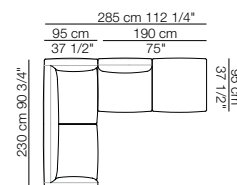

R 04

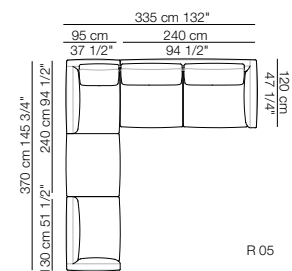

R 05

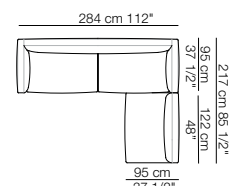

R 06

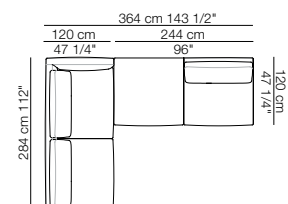

R 08

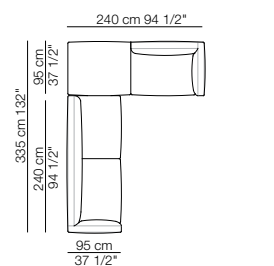

R 09

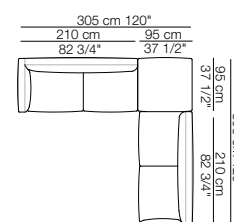

R 10

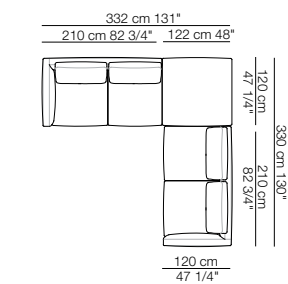

R 12

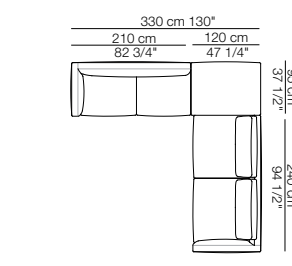

R 13

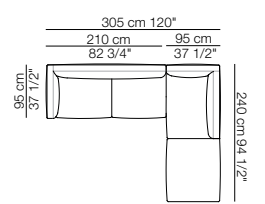

R 14

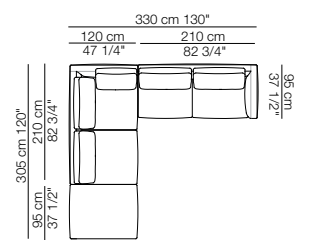

R 15



Strips 77

Poltrona
Armchair

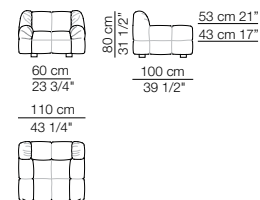

Divani
Sofas

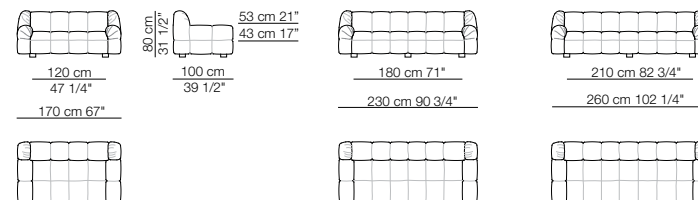

Strips

Divani
Sofas

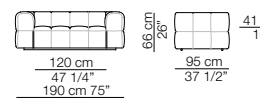

Elementi con 1 bracciolo
Units with 1 armrest

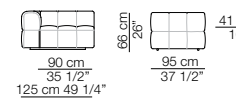

Elementi senza braccioli
Units without armrests

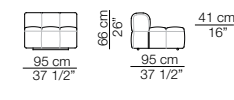

Divani P.125
Sofas D.125

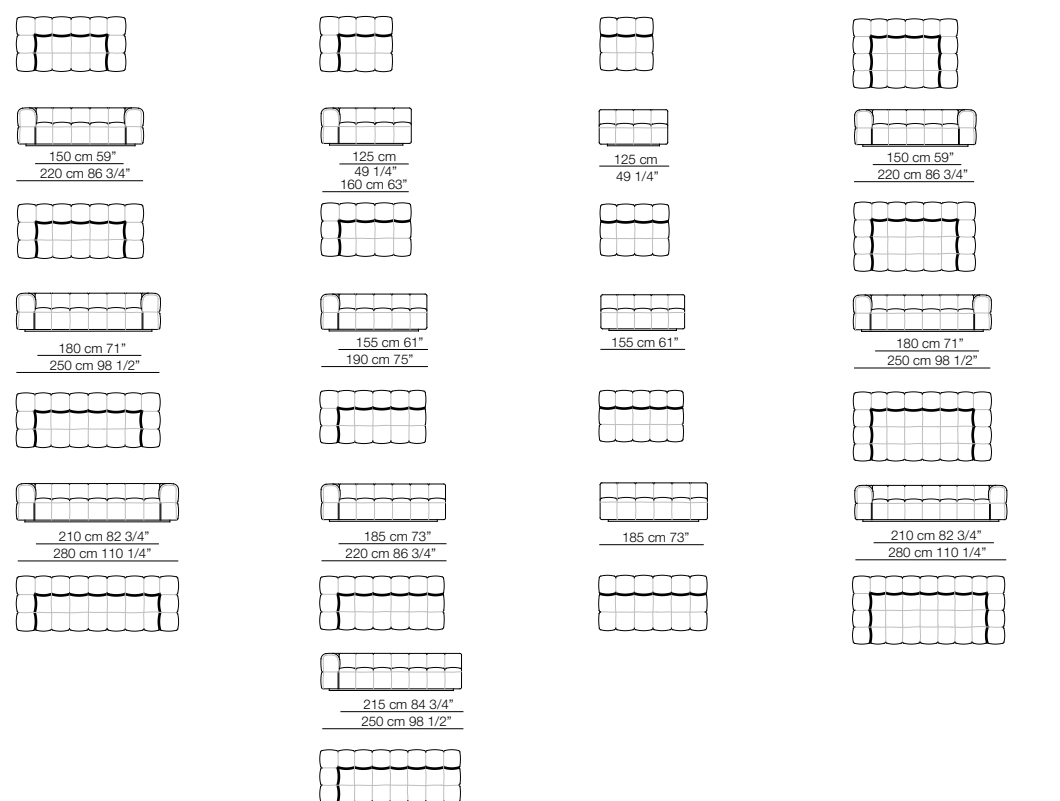
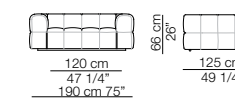



Divani con braccioli corti P.125
Sofas with short armrests D.125

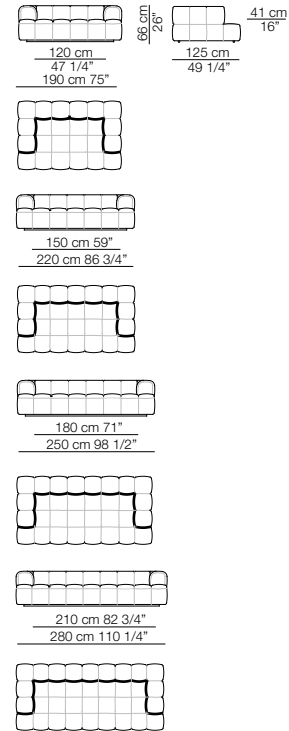

Elementi senza braccioli P.125
Units without armrests D.125

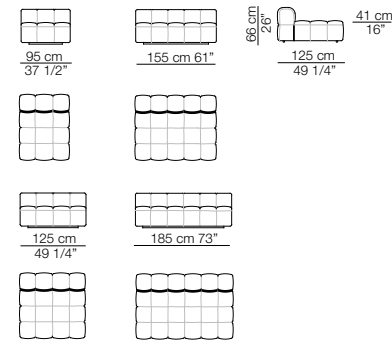

Elementi con 1 bracciolo P.125
Units with 1 armrest D.125

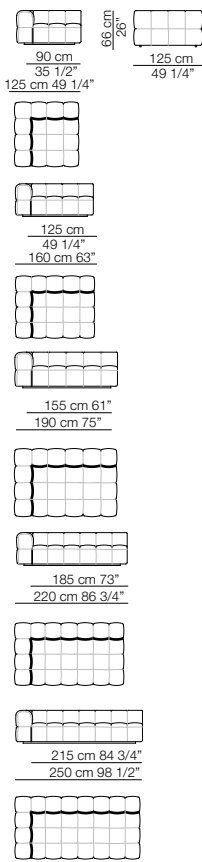

Pouf

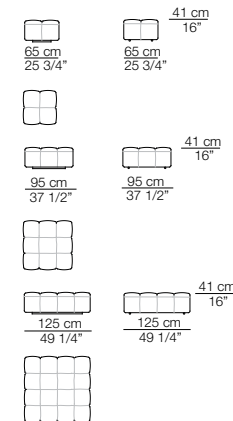

Elementi con 1 bracciolo corto P.125
Units with 1 short armrest D.125

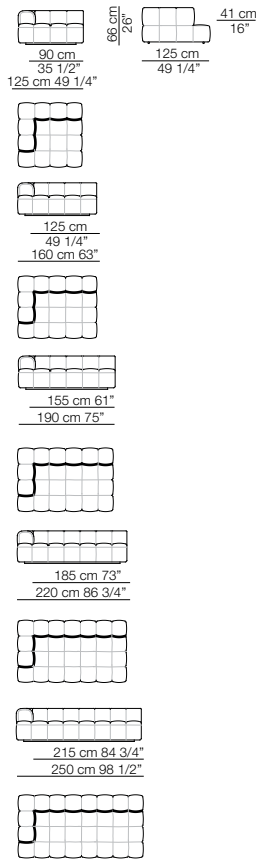

Cuscini arredo Soft
Soft loose cushions

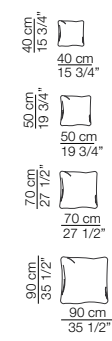

Composizioni
Compositions

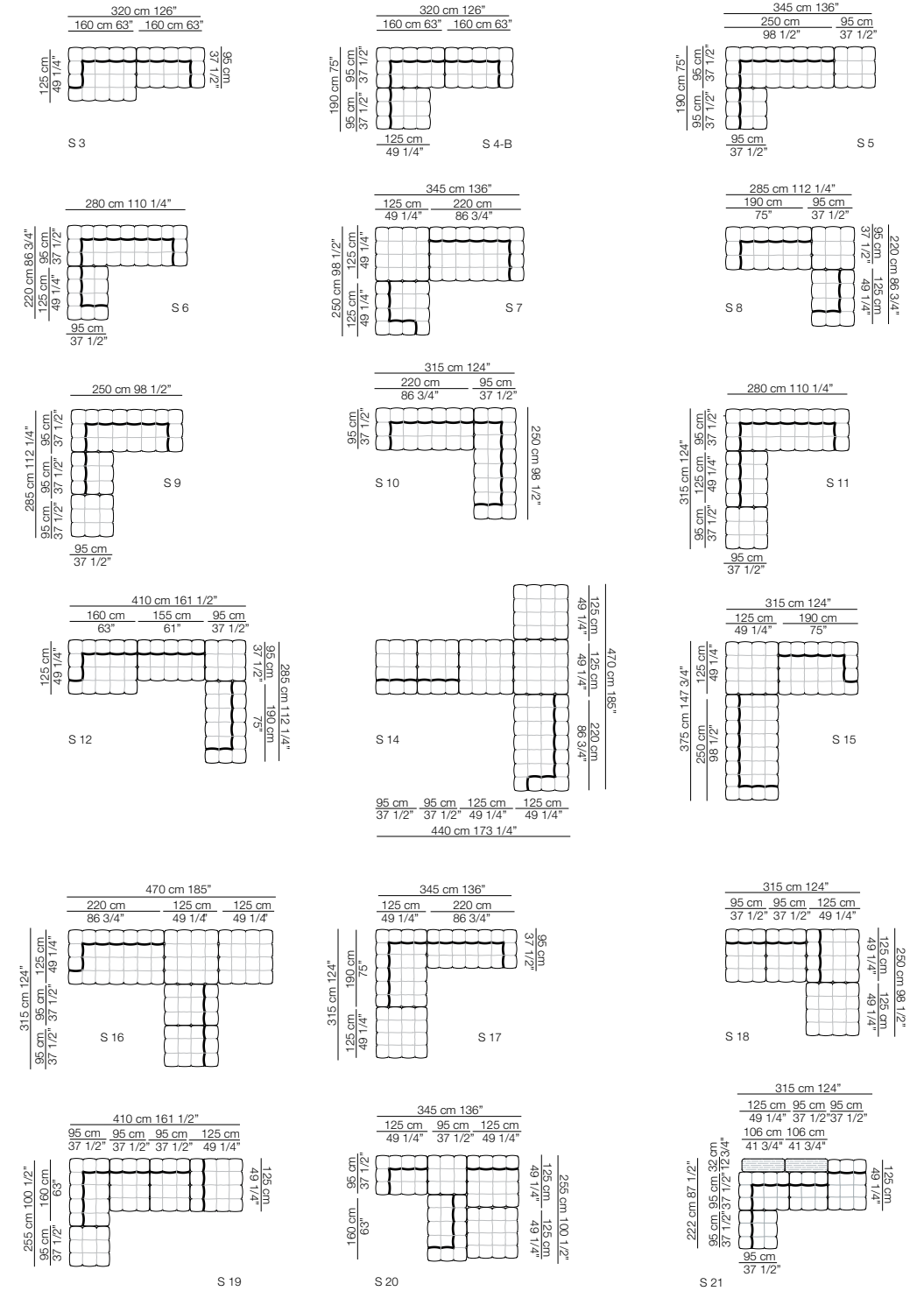

Divani / Sofas



Tokio

Divani
Sofas

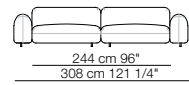
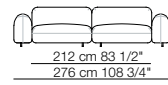
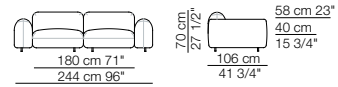

Elementi con 1 bracciolo P.106
Units with 1 armrest D.106

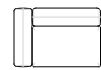
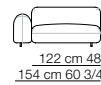
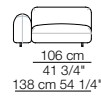
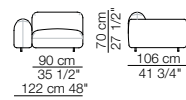

Elementi con 1 bracciolo P.122
Units with 1 armrest D.122

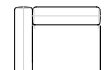
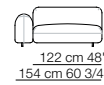
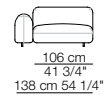
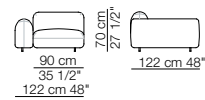

Elementi senza braccioli P.106
Units without armrests D.106

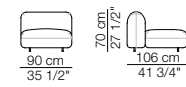

Elementi senza braccioli P.122
Units without armrests D.122

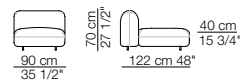

Elementi senza braccioli P.138
Units without armrests D.138

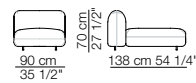

Elementi angolo P.106
Corner units D.106

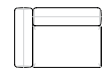
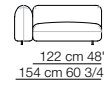
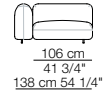
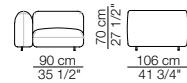

Elementi angolo P.122
Corner units D.122

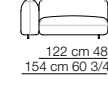
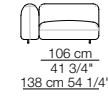
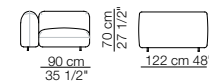

Divani / Sofas

Elementi Curvi
Curved elements

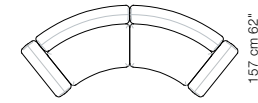
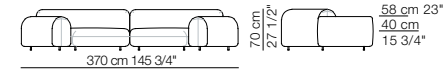
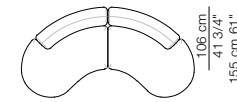
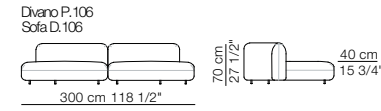

Elemento isola senza braccioli
Isle unit without armrests

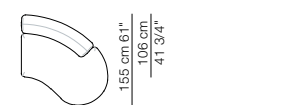

Elementi con 1 bracciolo
Units with 1 armrest

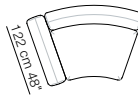
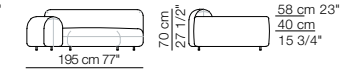
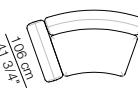
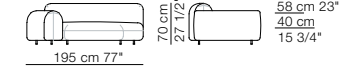

Elementi senza braccioli
Units without armrests



Elemento isola senza braccioli P.106
Isle unit without armrests D.106

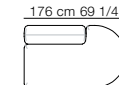
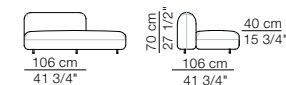

Pouf

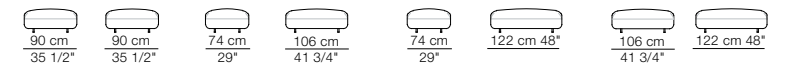
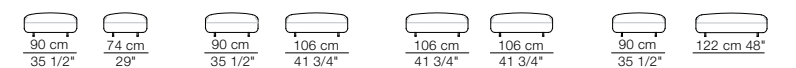

Moduli
Modules

Modulo con ripiano 106x32
Module with shelf 106x32

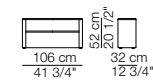

Modulo con cassetto 106x74
Module with drawer 106x74

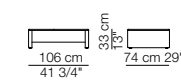

Modulo contenitore aperto 106x32
Open storage module 106x74

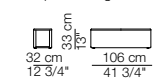

Cuscino di schienale 60x60
Backrest cushion 60x60

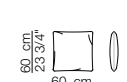

Composizioni
Compositions

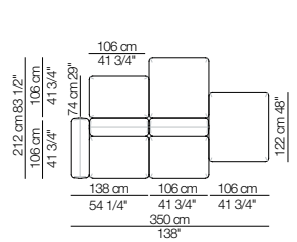

T 01

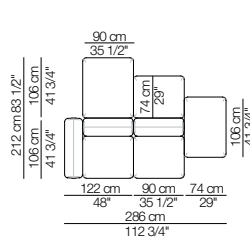

T 03

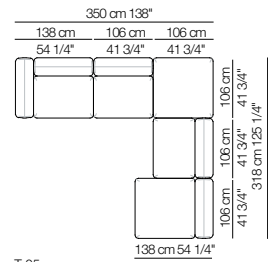

T 05

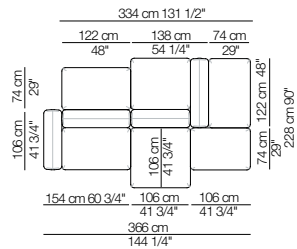

T 06

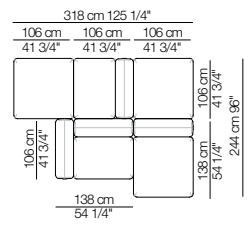

T 09

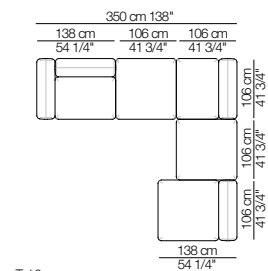

T 10

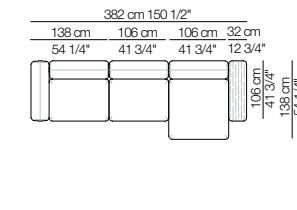

T 13

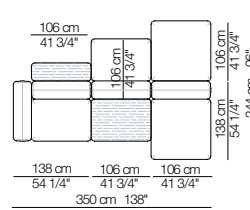

T 15

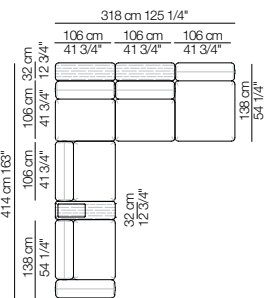

T 16

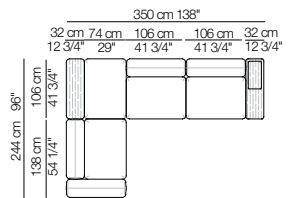

T 17/B

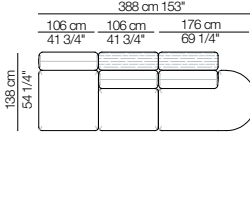

T 18

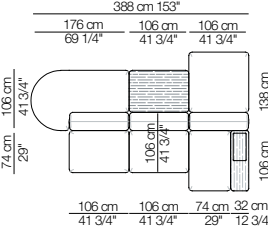

T 19

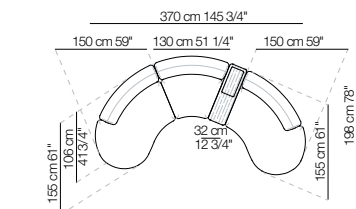

T 20

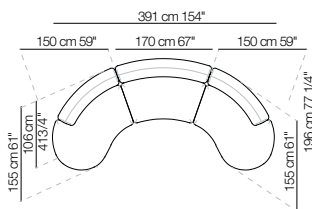

T 21

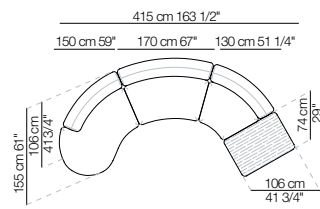

T 22

Composizioni
Compositions

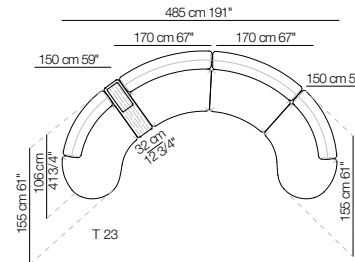

T 23

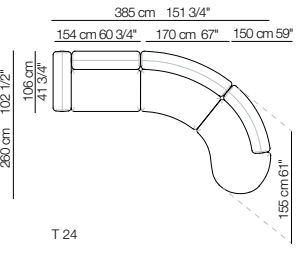

T 24

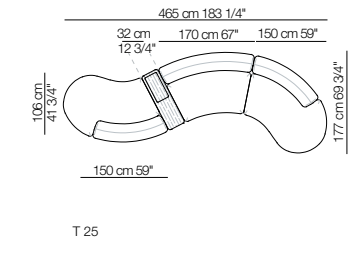

T 25

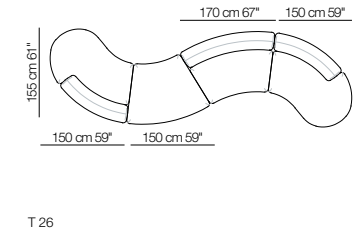

T 26

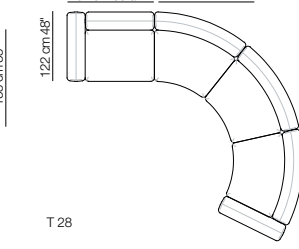

T 28

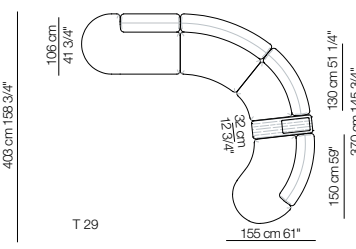

T 29

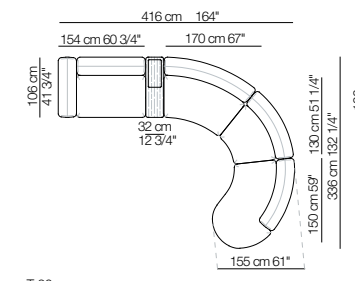

T 30

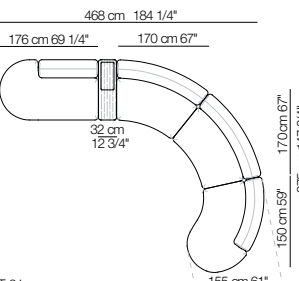

T 31

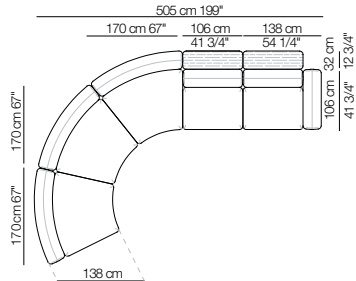

T 32

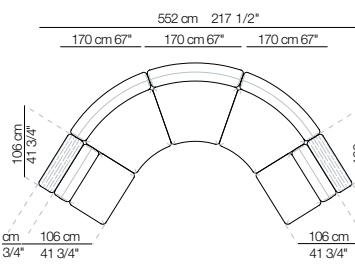

T 33

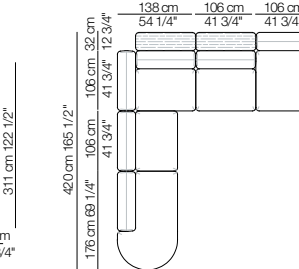

T 34

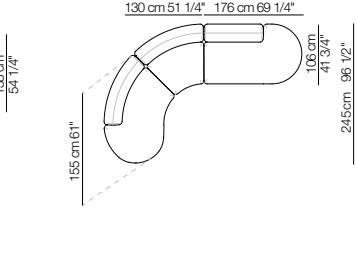

T 35

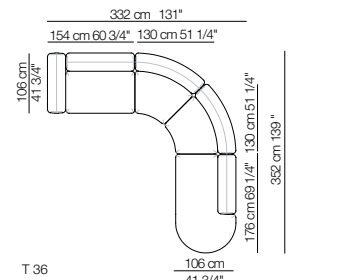

T 36

Poltrone / Armchairs

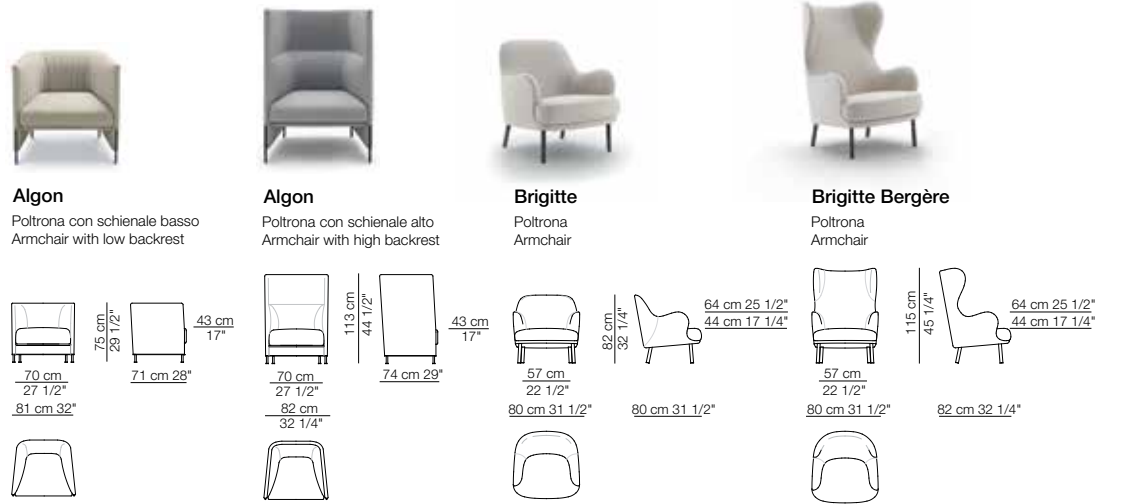

Algon
Poltrona con schienale basso
Armchair with low backrest

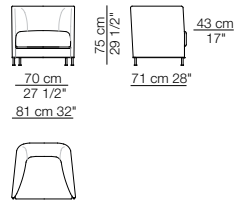

Algon
Poltrona con schienale alto
Armchair with high backrest

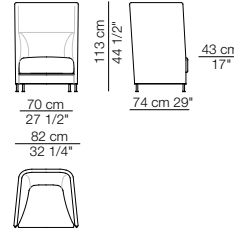

Brigitte
Poltrona
Armchair

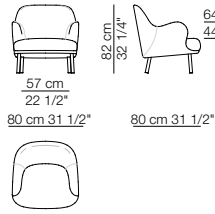

Brigitte Bergère
Poltrona
Armchair

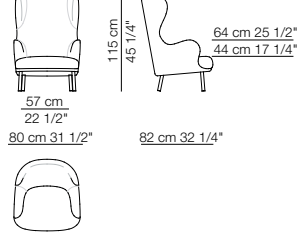

Botolo
Poltrona versione bassa
Armchair low version

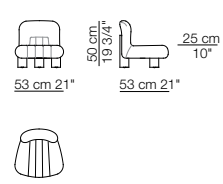

Botolo
Poltrona versione alta
Armchair high version

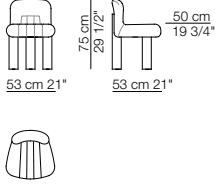

Cocca
Poltrona
Armchair

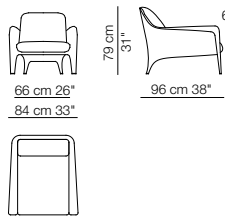

Cradle
Poltrona
Armchair

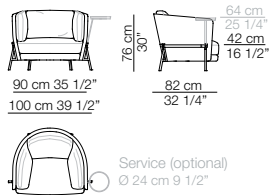

Delta Vienna
Poltrona
Armchair

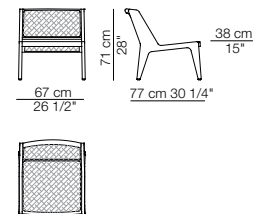

Poltrone / Armchairs

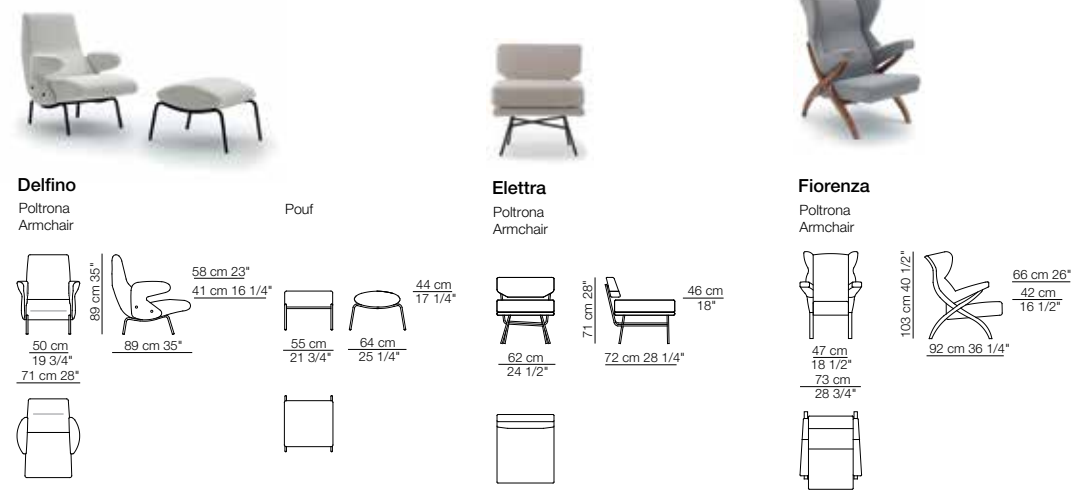

Delfino
Poltrona
Armchair

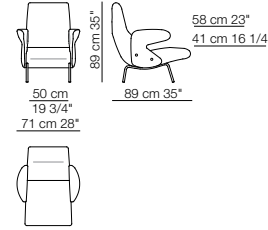

Pouf

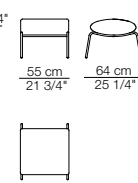

Eletra
Poltrona
Armchair

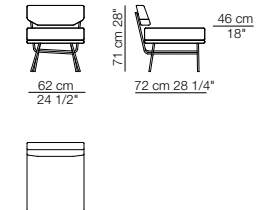

Fiorenza
Poltrona
Armchair

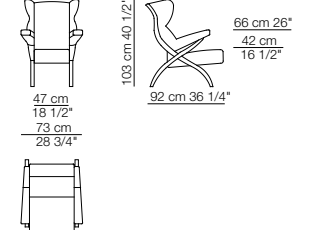

Giulietta
Poltrona
Armchair

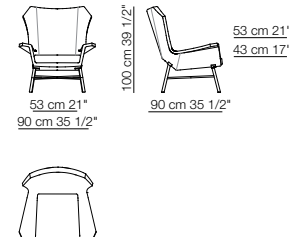

Hall
Poltrona
Armchair

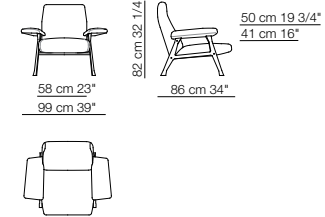

Hug
Poltrona con schienale basso
Armchair with low backrest

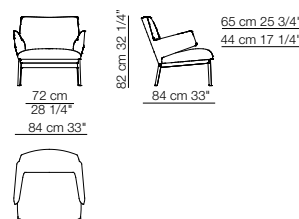

Hug
Poltrona con schienale alto
Armchair with high backrest

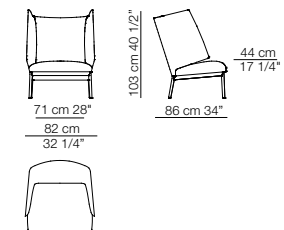

Poltrone / Armchairs



Jules
Poltrona
Armchair

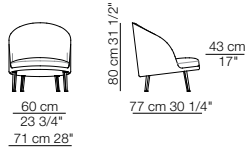

Jim
Poltrona
Armchair

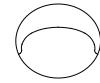
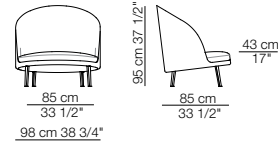

Katrin
Poltrona
Armchair

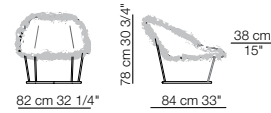

Pecorelle
Poltrona
Armchair

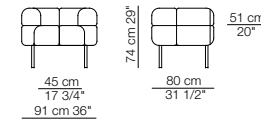

Solice
Poltrona
Armchair

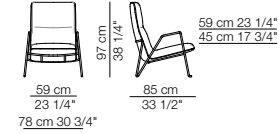

Pouf

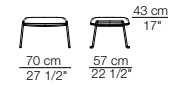

Ladle
Poltrona con schienale basso /
Basamento girevole a razze
Armchair with low backrest /
Swivel spoke base

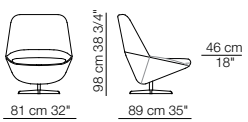

Ladle
Poltrona con schienale medio /
Basamento girevole a razze
Armchair with medium backrest /
Swivel spoke base

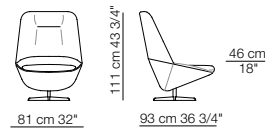

Ladle
Poltrona con schienale alto /
Basamento girevole a razze
Armchair with high backrest /
Swivel spoke base

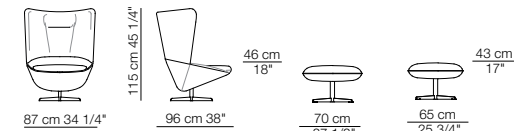

Pouf con basamento
a razze (non girevole)
Pouf with spoke base
(not swivel)

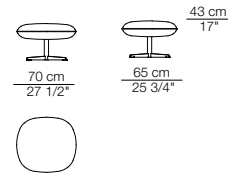

Poltrona con schienale basso /
Basamento in metallo
Armchair with low backrest /
Metal base

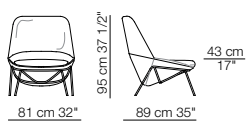

Poltrona con schienale medio /
Basamento in metallo
Armchair with medium backrest /
Metal base

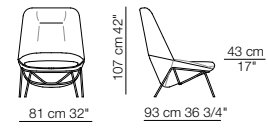

Poltrona con schienale alto /
Basamento in metallo
Armchair with high backrest /
Metal base

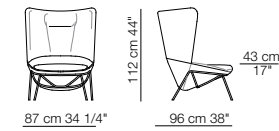

Strips 77
Poltrona
Armchair

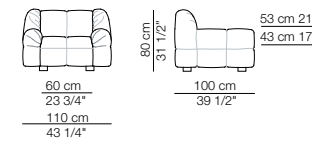

Suppli
Poltrona
Armchair

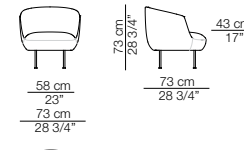

Taboga
Poltrona
Armchair

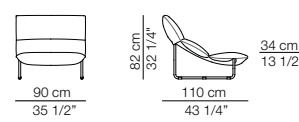

Yuzu
Poltrona
Armchair

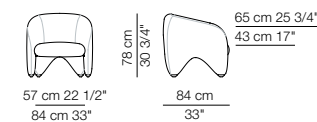

Pouf

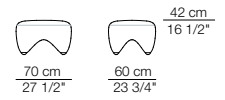

Sedie - Sgabelli / Chairs - Stools



Botolo
Poltrona versione bassa
Armchair low version

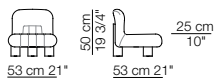

Botolo
Poltrona versione alta
Armchair high version

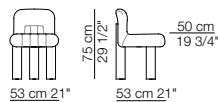

Elettra
Sedia
Chair

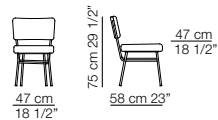

Lizzy
Sedia
Chair

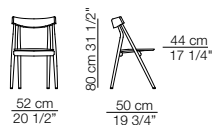

Neptunia
Sedia
Chair

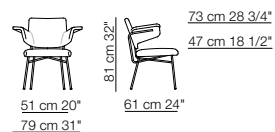

Orfeo
Sgabello H.92 cm
Stool H. 92 cm

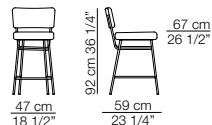

Sgabello H.102 cm
Stool H. 102 cm

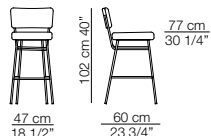

Dormeuse - Daybed



Bonsai
Divano con piedini in metallo
Sofa with metal feet

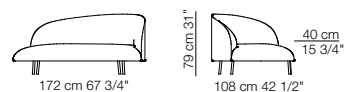

Cousy
Chaise longue con 2 braccioli
Chaise longue with 2 armrests

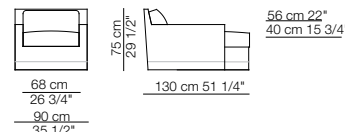

Divano con base in legno
Sofa with wooden base

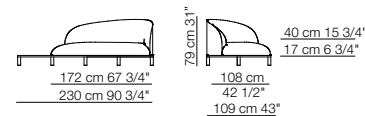

Sigmund
Panca
Bench

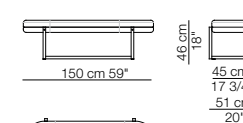

Boborelax
Dormeuse

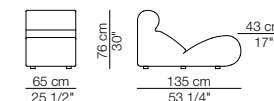

Sigmund
Daybed

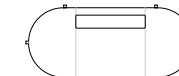
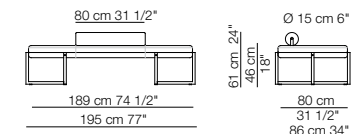

Tavolini / Small tables



Arcolor
Tavolino ø 30
Small table ø 30

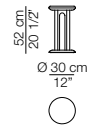

Arcolor
Tavolino ø 50
Small table ø 50

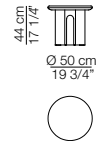

Arcolor
Tavolino ø 100
Small table ø 100

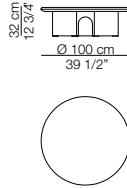

Bonsai
Tavolino
Small table

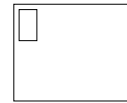
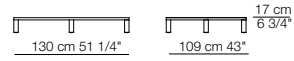

Capilano
Tavolino 55 x 55
Small table 55 x 55

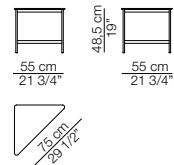

Capilano
Tavolino 96 x 30
Small table 96 x 30

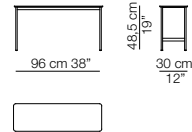

Capilano
Tavolino 187,5 x 30
Small table 187,5 x 30

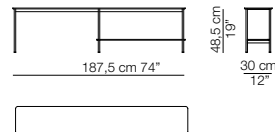

Cradle
Tavolino
Small table

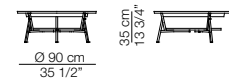

Tavolini / Small tables



Tablet
Tavolino ø 50 H.31 cm
Small table ø 50 H.31 cm



Tablet
Tavolino ø 50 H.43 cm
Small table ø 50 H.43 cm



Tablet
Tavolino ø 80 H.31 cm
Small table ø 80 H.31 cm

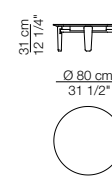

Tablet
Tavolino ø 80 H.43 cm
Small table ø 80 H.43 cm

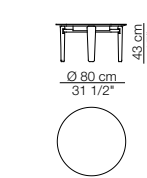

Tablet
Tavolino 109 x 109 H.31 cm
Small table 109 x 109 H.31 cm

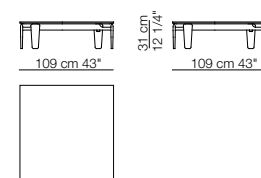

Tokio
Service Ø 40

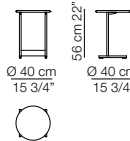

Tokio
Service 106 x 32

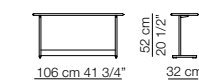

Tokio
Tavolino 106 x 106
Small table 106 x 106

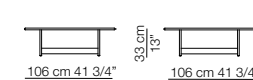

Tokio
Tavolino Ø 120
Small table Ø 120

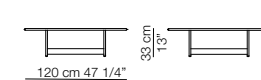

Marea
Tavolino H.30,5 cm
Small table H.30,5 cm

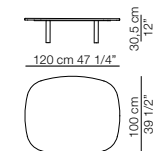

Marea
Tavolino H.35 cm
Small table H.35 cm

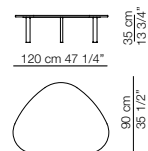

Match
Tavolino H.34 cm
Small table H.34 cm

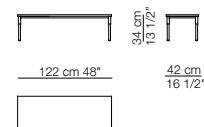

Match
Tavolino H.42 cm
Small table H.42 cm

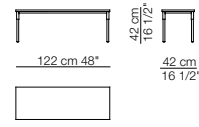

Tokio
Modulo con ripiano 106 x 32
Module with shelf 106 x 32

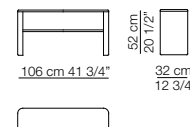

Tokio
Modulo con cassetto 106 x 74
Module with drawer 106 x 74

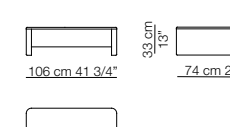

Tokio
Modulo contenitore aperto 106 x 32
Open storage module 106 x 32

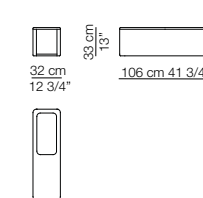



Alba versione fissaggio a soffitto
ceiling fixing version



Alba versione fissaggio a parete
wall fixing version

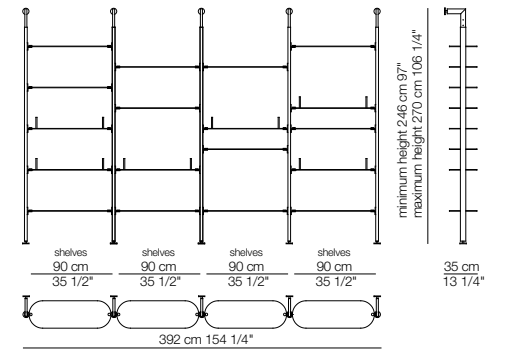
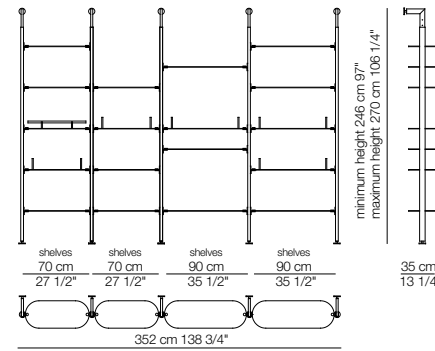
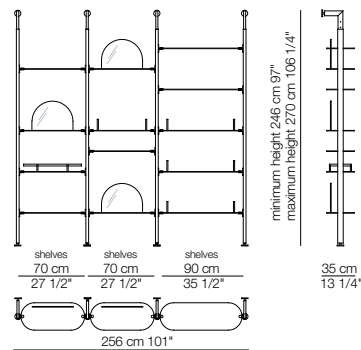
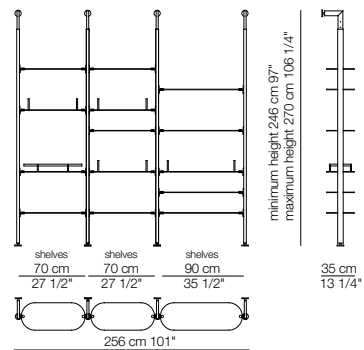
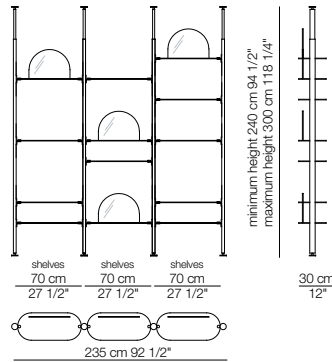
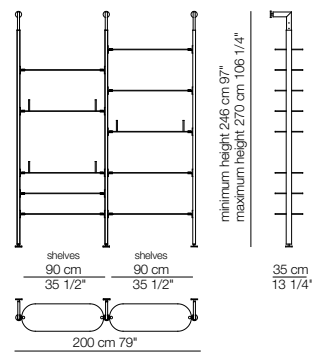
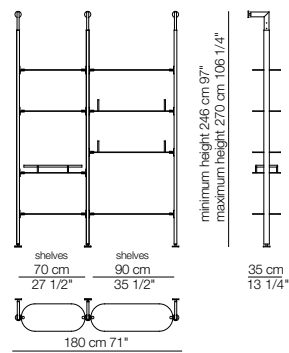
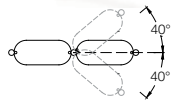

Ripiani in vetro
Glass shelves

Ripiano "A"
Shelf "A"

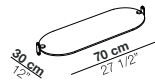

Fumè - Bronze - Green

Ripiano "B"
Shelf "B"

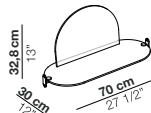

Fumè - Bronze - Green

Ripiani in alluminio 70 cm
Aluminium shelves 70 cm

Ripiano "C"
Shelf "C"

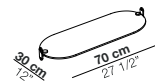

Ripiano "D" - Kit fermalibri
Shelf "D" - Bookend kit

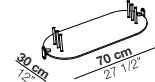

Ripiano "E" - Ring contenitore
Shelf "E" - Storage ring

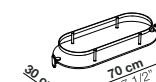

Ripiani in alluminio 90 cm
Aluminium shelves 90 cm

Ripiano "F"
Shelf "F"

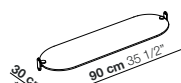

Ripiano "G" - Kit fermalibri
Shelf "G" - Bookend kit

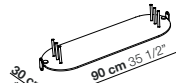



Delfino
Pouf

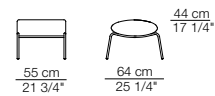

Pouf
Pouf

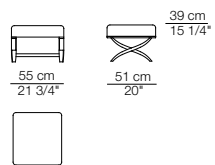

Ciclope
Specchio
Mirror

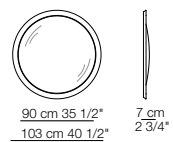

Penta
Pouf

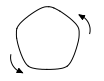
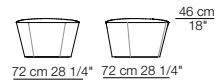

Solice
Pouf

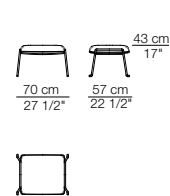

Penta
Pouf

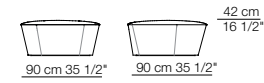

Yuzu
Pouf

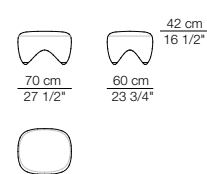

Penta
Pouf

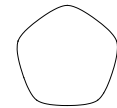
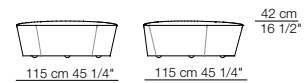

Diva

Accessorio
Accessory

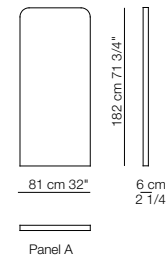

Accessorio
Accessory

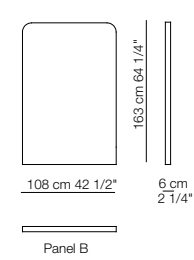

Accessorio
Accessory

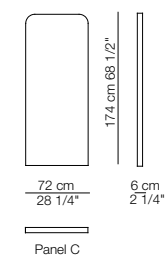

Accessorio
Accessory

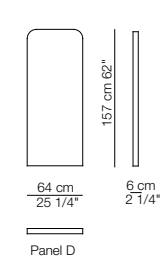

Accessorio
Accessory

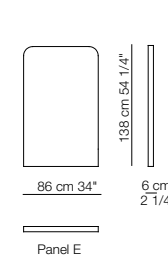

Accessorio
Accessory

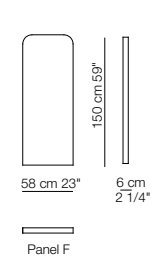

Match

Console

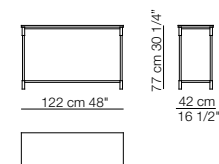

Papillon

Lampada da parete
Wall lamp

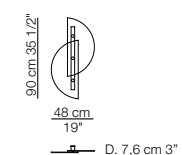

Ponti

Scrittoio
Writing desk

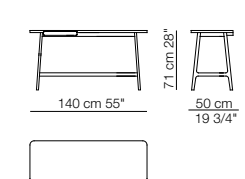

Radia

Scultura decorativa a parete
Decorative wall sculpture

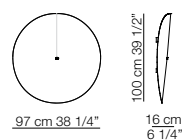



Threshold

Mobile specchiera basso
Low mirror cabinet

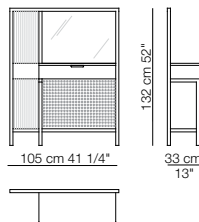

Threshold

Mobile specchiera alto
High mirror cabinet

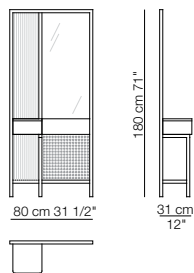

Vela

Paravento
Screen

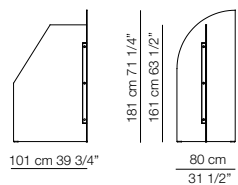

Code **A**
Colori : rosa e azzurro
Colours : pink and light blue



Vela

Paravento
Screen

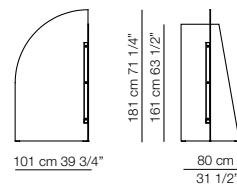

Code **C**
Colori : verde e azzurro
Colours : green and light blue



Vela

Paravento
Screen

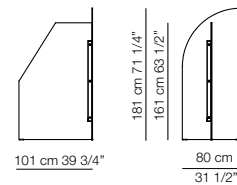

Code **D**
Colori : rosa e bronzo
Colours : pink and bronze

Letti / Beds



Palazzo

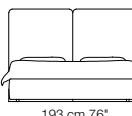
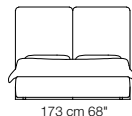
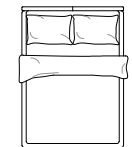
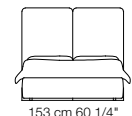
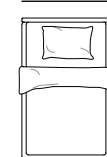

**Kit pannelli laterali
Side panels kit**

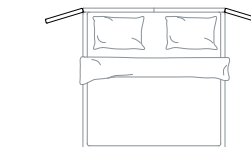
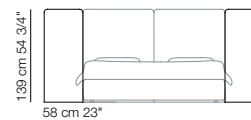

Letti / Beds



Strips

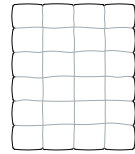
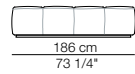
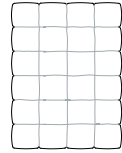
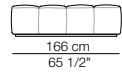
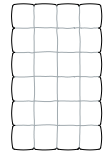
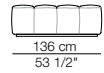
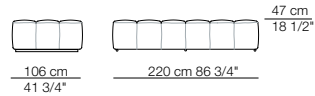

Strips divano letto
Strips sofa-bed

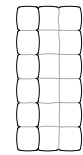
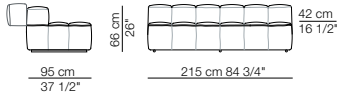

Suite

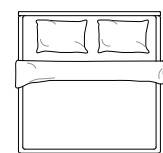
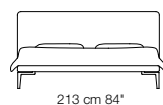
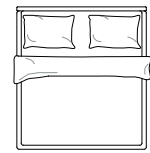
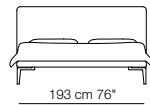
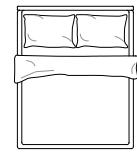
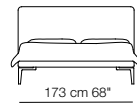
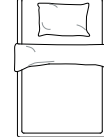
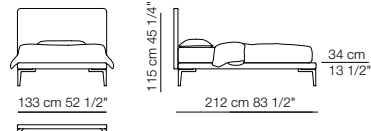

Outdoor / Outdoor



Cloud collection

Poltrona
Armchair

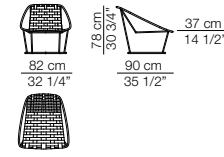

Divanetto
Small sofa

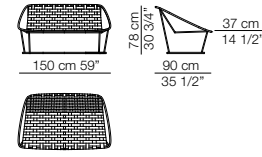

Marengo outdoor

Poltrona
Armchair

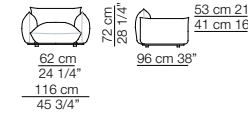

Divani
Sofas

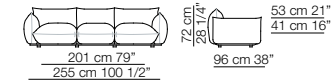
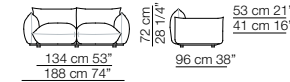

Pouf

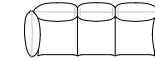
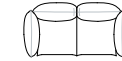
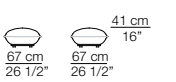

Taboga outdoor

Poltrona
Armchair

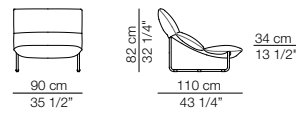

arflex

via Pizzo Scalino 1
20833 Giussano (MB) Italy
t +39 39 0362 853043
f +39 0362 354010
info@arflex.it
www.arflex.com

Follow us on:



Printed May 2024

AD Catalogue

Bernhardt & Vella

Ph. Pagani Thomas

Copyright 2025
seven salotti spa
All rights reserved

arflex, qualora ne ravvisi la necessità e per non arrestare il continuo processo di miglioramento ed aggiornamento tecnico della produzione, si riserva di apportare ai suoi prodotti, senza alcun preavviso, tutte le modifiche tecniche e strutturali che riterrà opportune. I colori, le finiture, le illustrazioni e le descrizioni del presente catalogo sono a titolo indicativo e non vincolanti.

arflex, if necessary and in order not to stop the continuous improvement process and updating of the technical production, reserves the rights to change its models, without giving prior notice, improving them with all the technical and structural modifications considered appropriate. The colours, finishing, illustrations and descriptions in this catalogue are provided solely by way of example.